

**IFAE Report of Activities  
Year 2007**



## IFAE REPORT OF ACTIVITIES – YEAR 2007

1. Resum.....	1
2. Resumen.....	11
3. Summary.....	21
4. About IFAE.....	31
4.1 Structure.....	31
4.2 IFAE Goals.....	31
4.3 IFAE Governing Board.....	33
5. IFAE Personnel.....	35
6. Institutional Activities.....	41
6.1 Diploma Theses .....	41
6.2 Doctoral Theses .....	41
6.3 Publications.....	41
6.4 Talks by IFAE members.....	45
6.5 Participation in External Committees.....	48
6.6 Seminars organized by IFAE.....	49
7. Scientific Activities.....	53
The Experimental Division .....	55
7.1 ATLAS at the CERN LHC.....	55
7.2 The Collider Detector at the Tevatron (CDF).....	63
7.3 Neutrino Experiments at IFAE.....	67
7.4 The MAGIC Telescopes.....	71
7.5 The CTA (Cerenkov Telescope Array) Project.....	75
7.6 The DES (Dark Energy Survey) Project.....	77
7.7 The PAU (Physics of the Accelerating Universe) Project.....	83
7.8 The X-Ray Projects .....	89
The Theory Division .....	93
7.9 Quantum Information Theory .....	93
7.10 Theoretical Astroparticle and Particle Cosmology.....	95
7.11 Physics of the Fundamental Interactions.....	97



# 1. RESUM

Versión en Castellano en la página 11

English version on page 21

En aquesta memòria es descriuen les activitats de l'Institut de Física d'Altes Energies (IFAE) a l'any 2007.

## Estructura de l'IFAE

L'IFAE és un consorci entre la Generalitat de Catalunya i la Universitat Autònoma de Barcelona (UAB). El consorci va ser creat el 16 de juliol de 1991 pel decret 159/1991 del Govern de la Generalitat. Com a consorci, l'IFAE és una entitat legal amb personalitat jurídica pròpia. La relació formal amb la Generalitat es porta a terme a través del Departament d'Innovació, Universitats i Empresa (DIUE; anteriorment, DURSI).

L'IFAE integra el seu propi personal amb personal dels Grups de Física Teòrica i de Física d'Altes Energies del Departament de Física de la UAB. La llista del personal està a la pàgina 33.

Els òrgans de govern de l'Institut són el Consell de Govern i el Director. Les línies generals d'investigació, la contractació de personal, el pressupost anual i la creació i la supressió de Divisions són algunes de les responsabilitats del Consell de Govern, el qual també designa al Director a partir d'una llista de candidats proposats pel rector de la UAB. El Director és responsable de l'execució de les decisions del Consell de Govern. Els Coordinadors de les Divisions són proposats pel director i designats pel Consell de Govern. Els membres del Consell de Govern durant 2007 figuren a la pàgina 32.

L'IFAE té també l'estatut d'Institut Universitari adscrit a la UAB. Aquesta fórmula permet al personal de l'IFAE participar en el programa docent de la UAB, en particular donar cursos de doctorat.

En 2004 l'IFAE es va unir a les seves institucions fundacionals, la UAB i el DURSI, així com al CIEMAT (Centre d'Investigacions Energètiques i Mediambientals, una organització d'investigació de caràcter estatal amb seu a Madrid), per a crear i

promoure el Port d'Informació Científica (PIC). Aquest centre, situat en el campus de la UAB, molt a prop de l'IFAE, té com objectiu donar suport a projectes científics que requereixin l'accés distribuït a enormes quantitats de dades, tals com els futurs experiments a l'accelerador LHC del CERN. A l'IFAE se li ha encarregat per les altres institucions que formen el consorci la gestió administrativa del PIC. El PIC té el seu propi Director i Consell de Govern. Les activitats del PIC es descriuen a les seves pròpies memòries.

## Objectius de l'IFAE

Tal com figura en el Decret 159/1991 del Govern de la Generalitat de Catalunya, l'objectiu de l'IFAE és realitzar investigació i contribuir al desenvolupament de la Física d'Altes Energies, tant en la seva vessant teòrica com experimental.

Els orígens del consorci estan en el Departament de Física Teòrica i en el Laboratori de Física d'Altes Energies (LFAE) de la UAB. El grup teòric va ser establert al 1971, quan es va crear la universitat. El Laboratori de Física d'Altes Energies va ser creat al 1984, amb l'objectiu d'iniciar la investigació en aquesta disciplina a la UAB, en particular per a aprofitar de manera eficaç la pertinença al laboratori internacional CERN, després que Espanya va tornar a formar part del mateix al 1982. Com es menciona en el Decret 159/1991, l'existència del LFAE i de grups d'investigació teòrics a Catalunya, el desig de reforçar la investigació de la Física d'Altes Energies, en particular en la vessant experimental, i el desig de col·laborar en l'esforç del Govern espanyol per a desenvolupar aquest camp, va conduir a les autoritats de la Generalitat a crear l'IFAE al 1991.

En els anys següents la divisió experimental de l'IFAE va passar d' un personal de 15 a aproximadament 67 persones. El programa experimental s'ha també eixamplat, tant en el nombre de projectes com en la seva temàtica. Al 1992 el grup estava involucrat tant sol en un experiment de física de partícules, anomenat ALEPH, a l'accelerador LEP del CERN, mentre que actualment hi ha quatre línies diferents d'investigació bàsica: física de partícules en col·lisionadors d'hadrons, amb ATLAS i CDF; física de neutrins, amb K2K i T2K; astrofísica d'altres energies, amb els telescopis de MAGIC, i

cosmologia observacional, que començà al 2005, amb el projecte DES sobre l'energia fosca. Aquesta última línia es reforçà a 2007, amb l'aprovació d'un projecte Consolider-Ingenio 2010, liderat per l'IFAE. Addicionalment, hi ha una línia d'investigació força activa en física aplicada, enfocada en el desenvolupament de noves tècniques de radiografia digital i de lectura de circuits electrònics d'alta densitat. A més, existeix una col·laboració molt estreta amb el Port d'Informació Científica (PIC) en els aspectes computacionals dels experiments de l'IFAE que ja produeixen o bé estan a punt de produir dades.

La Divisió Teòrica ha ampliat també el seu programa d'investigació des que l'IFAE va ser creat. Actualment hi ha tres línies principals d'investigació: física de les interaccions fonamentals, astrofísica d'altres energies i informació quàntica.

El fet que l'IFAE tingui personalitat jurídica pròpia li ha permès assumir la gestió dels seus propis projectes així com d'alguns projectes externs.

Des del 1995 al 2001 el Laboratori de Llum Sincrotró (LLS) va estar administrativament dintre de l'IFAE. Aquest laboratori va ser l'organització que va proposar la construcció d'una Font de Llum de Sincrotró a Barcelona, un projecte aprovat tant pel govern espanyol com pel govern de Catalunya al 2003, ara en construcció.

L'IFAE va ser també la institució responsable de la construcció de l'edifici dedicat al funcionament dels telescopis de MAGIC al Roque de los Muchachos a l'illa de La Palma i és a l'actualitat la institució gestora dels "Fons Comuns" (les despeses de funcionament i operació) de la col·laboració MAGIC.

Des del 1999 a 2004 l'IFAE ha estat també la institució responsable del seguiment, tant tècnic com administratiu, d'un contracte entre el CERN i una empresa espanyola, per a la construcció de recipients de buit de l'imant toroidal del detector ATLAS, tal com s'explica més endavant.

A continuació es donen unes descripcions molt breus dels projectes d'investigació de l'IFAE a les Divisions Experimental i Teòrica. Les descripcions més detallades es poden trobar al capítol 7.

## 1.1 La Divisió Experimental al 2007

Durant 2007 les activitats de la Divisió Experimental es centraren en vuit projectes, la majoria dels quals estan en marxa des d'uns anys:

- ATLAS, un experiment en preparació per al Large Hadron Collider del CERN, el Centre Europeu per a la Física de Partícules, que prendrà dades al 2008;
- CDF, un experiment de col·lisions antiprotó-protó que es porta a terme en el Laboratori Nacional de Fermi (FNAL), a Illinois, EUA.
- T2K, un experiment d'interaccions de neutrins situat al Japó que es posarà en marxa al 2009; a més, s'està estudiant un possible experiment situat al Laboratori Subterrani de Canfranc (Osca).
- MAGIC, un experiment d'astrofísica de raigs gamma que està prenent dades a les Illes Canàries; MAGIC acabarà la construcció d'un segon telescopi Čerenkov al 2008;
- CTA, un conjunt de molts telescopis Čerenkov, actualment en fase de disseny.
- DES (Dark Energy Survey), que construeix una càmera per a observar uns 300 milions de galàxies a l'hemisferi sud, per a estudis de cosmologia;
- PAU (Physics of the Accelerating Universe), una col·laboració espanyola que es va formar amb el suport d'un projecte Consolider-Ingenio 2010; PAU es dedicarà a estudis cosmològics fent servir observacions del cel de l'hemisferi nord amb un nou telescopi, que es construirà a Aragó;
- Noves tècniques de radiografia digital i de lectura de semiconductors d'alta densitat, aprofitant dels resultats de DearMama, un projecte de l'IFAE finançat per la Unió Europea que va desenvolupar una càmera digital de raigs-X d'alta resolució i contrast i amb una dosi de radiació al pacient força baixa. Els estudis es porten a terme en col·laboració amb una empresa *spin-off* de l'IFAE, X-Ray Imatek.

## L'Experiment ATLAS al LHC del CERN

ATLAS és un dels dos detectors del Large Hadron Collider (LHC), l'accelerador construït al CERN, on es faran xocar protons contra protons aconseguint una energia total de 14 TeV, la més gran assolida fins al moment en un laboratori. ATLAS investigarà un ampli ventall de física, incloent la recerca del bosó de Higgs, dimensions extra, i noves partícules que podrien formar part de la matèria fosca.

El detector ATLAS és un aparell molt complex, constituït per diversos subsistemes, i construït en dotzenes de laboratoris d'arreu del món. Actualment més de 2100 científics de 167 universitats i laboratoris de 37 països treballen en l'experiment ATLAS.

L'IFAE participa de manera important a ATLAS. El nostre institut va ser on es va muntar un dels subdetectors més grans d'ATLAS, el calorímetre hadrònic o Tilecal (abreviació de Tile Calorimeter). Aquest detector consta de tres "barrils", cada un d'ells fet de 64 mòduls. L'any 2002 l'IFAE va acabar la producció d'un barril complet (64 mòduls de 12 tones cada un, més un de recanvi). L'IFAE també va dissenyar i fabricar l'electrònica de

calibració del Tilecal. El Tilecal va ser el primer detector que va ser instal·lat a la caverna de l'experiment ATLAS l'any 2005. Un cop instal·lat es van dur a terme tests extensius de l'electrònica del sistema de lectura i de la calibració, en els quals l'IFAE va jugar, i encara juga, un paper molt important.

A més del treball en el detector, l'IFAE està molt involucrat en altres aspectes de l'experiment ATLAS, com ara:

- a) Contribucions al sistema de "trigger" d'ATLAS, en particular a la infraestructura del Filtre d'Esdeveniments, funcionament i tasques d'integració del trigger, i estudis del nivell-1 i del nivell-2 del trigger.
- b) Programa de física d'ATLAS: preparació de les anàlisis que busquen nova física mitjançant l'estudi de possibles processos de soroll, utilitzant dades simulades.
- c) Infraestructura de càlcul: administració i funcionament d'un centre Tier 2 i un centre Tier 3.
- d) Participació a la gestió d'ATLAS.

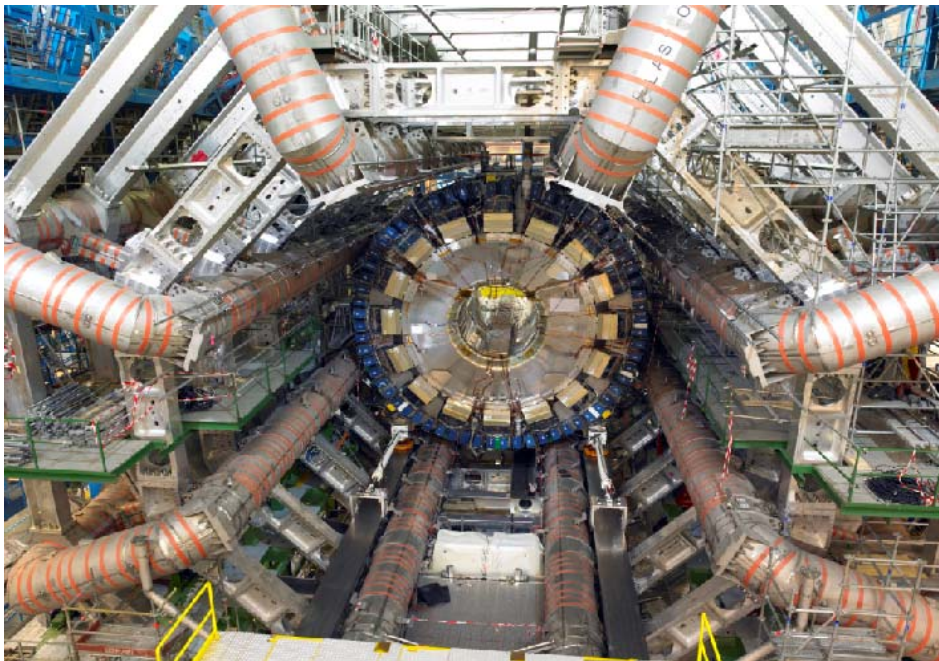

*Vista del calorímetre central en la seva posició final, juntament amb els imants toroidals.*

## CDF (Collider Detector at Fermilab)

Amb la finalitat de preparar-se per a les anàlisis de física del LHC, en 2003 un grup de científics del IFAE va decidir participar en l'experiment CDF al colisionador Tevatron (Fermi National Accelerator Laboratory, EUA), on es produeixen col·lisions entre protons i antiprotons amb una energia en el centre de masses de 2 TeV. L'experiment CDF va descobrir el quark top en 1995 i des de l'any 2001 pren de nou dades amb un detector altament millorat.

El programa de física del Tevatron i del LHC són similars i fins que s'engegui el LHC a la tardor de 2008 el Tevatron es manté com l'accelerador amb més energia del món. L'increment de lluminositat de l'accelerador ha permès mesures de precisió i pot donar lloc al descobriment de nova física en el futur.

Des de 2003, el grup de IFAE a CDF ha pres la responsabilitat del control de qualitat de les dades de l'experiment (DQM). El grup del IFAE també juga un paper capdavanter en l'anàlisi de les dades amb jets d'hadrons en l'estat final, així com en la recerca de super-simetria (SUSY) en CDF. Durant 2007, el grup ha consolidat encara més la seva presència dintre de CDF i membres del grup actuen com coordinadors dels grups de QCD, SUSY i Operacions del Detector.

En 2007, el grup del IFAE va publicar nous resultats de seccions eficaces de producció inclusiva de jets, Phys. Rev. D 75, 092006 (2007). El grup també va completar un estudi de la producció de jets en successos amb un bosó Z en l'estat final, estudi que va ser enviat per a la seva publicació en 2007 i recentment publicat en Phys. Rev. Lett. 100, 102001 (2008). A més, es van obtenir resultats finals de la recerca inclusiva de squarks i gluïns en SUSY. Els resultats han millorat sensiblement els límits actuals en les masses d'aquestes partícules, i es troben en procés de publicació.

La força del grup va quedar demostrada en 2007 amb 13 comunicacions en conferències i workshops, incloent una xerrada plenària a la Lepton-Photon Conference a Korea, considerada la conferència més important en el camp de la física de partícules en 2007.

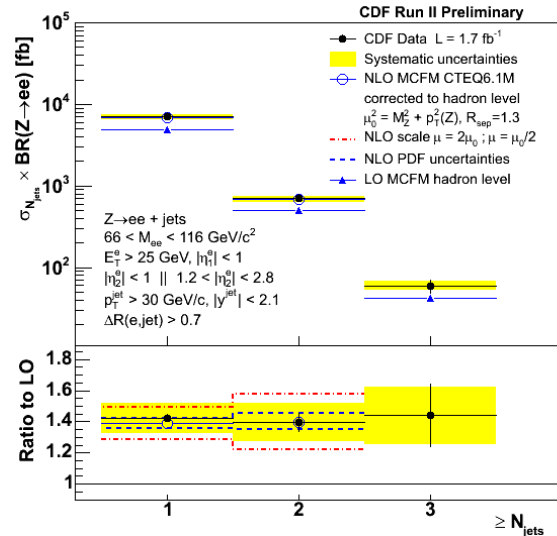

Secció eficaç de producció de successos Z+jets.

Dos estudiants del grup van defensar les seves tesis doctorals a la primavera del 2007 i continuen les seves carreres científiques amb posicions post-doctorals en universitats de primera categoria en EUA i Alemanya.

En estreta col·laboració amb el PIC, el grup de IFAE en CDF manté el cluster d'ordinadors BCNAF, fonamental per als projectes d'anàlisi del grup, i que ha estat usat per a la producció massiva d'esdeveniments simulats per part de CDF. En 2007, la capacitat de la granja va incrementar-se un 20% i ha mantingut una ocupació de gairebé el 100%.

## Experiments de Neutrins

K2K és un experiment d'oscil·lacions de neutrins en el qual un feix de neutrins produït en el laboratori KEK en la costa est de Japó és enviat a la mina de Kamioka a 250 quilòmetres de distància en la costa oest de Japó. Els neutrins travessen la terra gairebé sense interaccionar. L'experiment mesura el flux de neutrins de tipus muó després del punt de producció en el laboratori KEK i en la mina Kamioka. Per a això són operats dos detectors, un a 200m del punt de producció i altre llunyà en la mina Kamioka, anomenat Super-Kamiokande, que consisteix en un tanc de 50.000 tones d'aigua ultrapura. El flux es mesura detectant el nombre d'interaccions de



neutrins del tipus corrent carregada quasielàstica. Les mesures del detector proper s'utilitzen per a predir el nombre d'interaccions en el detector llunyà que es compara amb les mesures que allí es realitzen. Un dèficit en aquest nombre és una indicació del fenomen conegut com oscil·lacions de neutrins. L'any 2007 va ser l'últim que el IFAE va mantenir una activitat significativa en aquest experiment que va acabar la presa de dades en l'any 2004.

El IFAE està involucrat en la segona generació d'aquests experiments d'oscil·lacions denominat T2K. La principal diferència és la intensitat del feix de neutrins, que es planeja que augmenti un factor 20. Per a això s'usarà un nou accelerador en construcció en el laboratori JPARC també en la costa est de Japó i a una distància de 300 km de Kamioka on s'envia el feix de neutrins. El grup del IFAE s'ha concentrat en el detector proper que serà un espectrometre localitzat a 280m del punt de producció dels neutrins. El detector està sent dissenyat per a optimitzar les sensibilitats respecte a aquell usat en K2K, per a això es planeja usar un imant de gran tamany però baixa intensitat (0.2 Tesla). Les partícules carregades que es produïxen en les interaccions de neutrins són detectades en un detector denominat càmera de projecció temporal (o Time Projection Chamber, TPC).

L'objectiu de l'experiment T2K és la mesura de la transició de neutrins de tipus muó a uns altres de tipus electró que aporten informació sobre els paràmetres que governen les oscil·lacions. L'experiment té grans aportacions d'institucions japoneses, europees i nord-americanes. El IFAE ha contribuït de forma significativa al disseny i a la producció i caracterització dels detectors que s'estan produint. Un prototip del detector final va ser provat al final de l'any 2007 mostrant un comportament excel·lent en les condicions nominals d'ús.

El primer prototip complet de la TPC es construirà durant l'any 2008 i serà instal·lat per a la seva operació durant l'any 2009 coincidint amb el primer feix de neutrins.

L'IFAE va començar a avaluar l'any 2006 la possibilitat de contribuir a la construcció i operació d'un experiment per al Laboratori Subterrani de Canfranc (LSC) al Pirineu d'Osca. El laboratori està

a uns 1000 metres de profunditat el que minimitza el flux de raigs còsmics que són una font de soroll en experiments de baixa radioactivitat. Aquestes són unes condicions excepcionals per a la realització d'experiments anomenats de desintegració doble beta. Aquest procés nuclear és molt excepcional, les seves vides mitjanes ultrapassen els  $10^{20}$  anys, però aporta informació fonamental sobre la naturalesa última dels neutrins. L'IFAE, juntament amb altres institucions espanyoles, ha proposat un experiment de desintegració doble beta basat en una TPC de Xenó gasós a alta pressió enriquit en un isòtop que és un candidat a emissor doble beta.

## **Els Telescopis MAGIC**

MAGIC és l'acrònim de Major Atmospheric Gamma-Ray Imaging Telescope (Gran Telescopi d'Imatge de Čerenkov Atmosfèric). El telescopi està situat en l'Observatori del Roque de los Muchachos a La Palma (Illes Canàries). El seu objectiu és l'estudi dels raigs gamma de molt alta energia que arriben a la Terra d'un nombre relativament petit de fonts. Aquests ens donen informació sobre els mecanismes que produïxen tal radiació, que figuren entre els més violents coneguts en el cosmos. Per altra banda la propagació de la radiació en distàncies cosmològiques és sensible a la geometria i al contingut de matèria del cosmos en si mateix. MAGIC observa la llum induïda per les interaccions dels raigs gamma entrants en la part superior de l'atmosfera. Aquesta llum és reflectida en un mirall segmentat de 17 m de diàmetre i és recollida per la càmera, localitzada en el focus. La càmera conté fotodetectors molt ràpids i sensibles.

El grup del IFAE va construir en la seva totalitat la càmera del telescopi i el seu sistema de control, així com l'edifici que allotja l'electrònica i els equips de presa de dades. A més és responsable del control general del telescopi.

El telescopi va començar la seva operació regular al 2004. En 2007 es va entrar en el tercer cicle d'observacions. Durant el darrer any s'han publicat 11 articles en revistes, molts dels quals han estat iniciats pels físics de l'IFAE, o n'han rebut contribucions importants, i s'ha completat una tesi doctoral.

Resumint, el més destacat de les observacions de 2007 en les quals ha estat directament implicat l'institut:

- observació de la resta de supernova Cas A i descobriment de la font d'origen desconegut MAGIC J0616+225;
- descobriment del primer forat negre de massa estel·lar que emet raigs gamma de molt alta energia, Cygnus X-1;
- observació de nombrosos Nuclis Galàctics Actius (AGN), incloent el descobriment de 1ES 1011+496, a un desplaçament al roig elevat,  $z=0.212$ ;
- es va observar variació molt ràpida, en l'escala de minuts, durant un centelleig de Mrk 501 i es va descobrir una correlació entre l'energia dels raigs gamma i els seus temps d'arribada, fenomen que s'espera si hi ha ruptura de la invariància de Lorentz deguda a fenòmens de Gravetat Quàntica. Els resultats de MAGIC posen límits estrictes en aquestes teories.
- límits superiors a l'emissió gamma de galàxies "starburst" i d'Explosions de Raigs Gamma (GRB)

En 2005 la col·laboració va començar la construcció d'un segon telescopi, MAGIC-II, que serà un clon tècnicament millorat de l'original MAGIC-I. MAGIC-II està situat a uns 100 m i observarà en coincidència amb MAGIC-I. Aquesta operació en "estèreo" permetrà millorar les resolucions espectral i angular, així com la supressió del soroll, incrementant la sensibilitat en un factor dos, i contribuirà a reduir el llindar d'observació en energia.

MAGIC-II utilitza nous fotosensors i una electrònica de digitalització més ràpida (amb mostres a 2-4 GHz). El telescopi s'engegarà al setembre de 2008. Durant 2007 s'ha completat la fase de disseny i prototipat. El IFAE és responsable del sistema de recepció de senyals analògiques per fibra òptica, co-responsable de la lectura i adquisició de dades, responsable del sistema de control dels dos telescopis, i organitza la instal·lació i posada en marxa del centre de dades del sistema de dos telescopis.

## **El Projecte CTA (Cherenkov Telescope Array)**

CTA ("Cherenkov Telescope Array") serà una instal·lació avançada per a l'astronomia de raigs gamma de molt alta energia des de terra basada en l'observació de radiació Čerenkov. Es fonamenta en el lideratge mundial i l'experiència en la tècnica del "Imaging Atmospheric Cherenkov Telescope" desenvolupada per les instal·lacions HESS i MAGIC. CTA serà un observatori molt gran, amb desenes de telescopis Čerenkov despleats en un observatori en l'hemisferi nord i altre en el sud, i un cost estimat en uns 15 M€. En aquest moment CTA està en fase d'estudi de disseny i hi participen uns 300 científics europeus.

IFAE ha participat activament en el naixement del projecte i en la creació de la col·laboració CTA, i és molt visible també en aquest moment la seva participació en l'estudi de disseny.

## **El Projecte "Dark Energy Survey" (DES)**

A partir del 2011, el projecte internacional "Dark Energy Survey" (DES), liderat per Fermilab (EUA), produirà un cartografiat de 5000 graus quadrats de l'hemisferi sud galàctic, mesurant posicions, formes i desplaçaments al roig d'uns 300 milions de galàxies i 15000 cúmuls. A més, DES observarà repetidament uns altres 10 graus quadrats de cel amb l'objectiu de mesurar les magnituds i desplaçaments al roig de més d'un miler de supernoves llunyanes del tipus Ia. Aquestes mesures serviran per a aprofundir en l'estudi de les propietats de l'anomenada "energia fosca", responsable de l'actual expansió accelerada de l'univers.

Per a dur a terme el cartografiat, la col·laboració DES està construint una càmera de gran camp (DECam) que s'instal·larà al focus primari del telescopi Blanco, de 4 metres, a Cerro Tololo (Xile). L'IFAE, juntament amb l'Institut de Ciències de l'Espai (ICE) i el CIEMAT, construirà el conjunt complet de les targes electròniques per a la lectura de DECam, i al mateix temps, dissenyarà tres de les quatre targes principals. Durant el 2007, el disseny de les targes a l'IFAE ha anat seguint el ritme previst, produint-se una primera versió funcional de

la Tarja de Transició i un primer disseny de la Tarja Mestre de Control.

En paral·lel al disseny de les targes electròniques, s'ha desplaçat des de l'ICE fins a l'IFAE un muntatge de proves de CCDs i electrònica, s'ha automatitzat i s'ha caracteritzat completament, produint mapes d'intensitat lluminosa en longitud d'ona, en intervals de 5 nm, des de 300 nm fins a 1200 nm. Una vegada caracteritzat, el sistema es podrà fer servir per estudiar les propietats dels CCDs de DES. De moment, el sistema ha estat exercitat provant CCDs petits que es fabriquen juntament amb els de DES. Els tests inclouen exposicions dels CCDs tant a llum visible com a raigs X provinents d'una font d'Americi 241, la qual cosa permet fer

una mesura absoluta de l'eficiència de transferència de càrrega dels CCDs.

Com a preparació per a l'anàlisi de les dades de supernoves de DES, uns quants membres de l'IFAE, l'ICE i el CIEMAT van unir-se el 2007 al programa de seguiment espectroscòpic de supernoves descobertes per l'Sloan Digital Sky Survey (SDSS-II), en el rang de desplaçaments al roig entre 0.1 i 0.4. El grup del IFAE va liderar una proposta al "Telescopio Nazionale Galileo" (TNG) a La Palma que va aconseguir quatre nits d'observacions el 2007. Les observacions van produir espectres de 25 objectes, entre els quals nou supernoves del tipus Ia, incloent-ne una de molt peculiar, la SN2007qd, i quatre del tipus II. Les observacions van ser publicades en tres circulars del CBET.

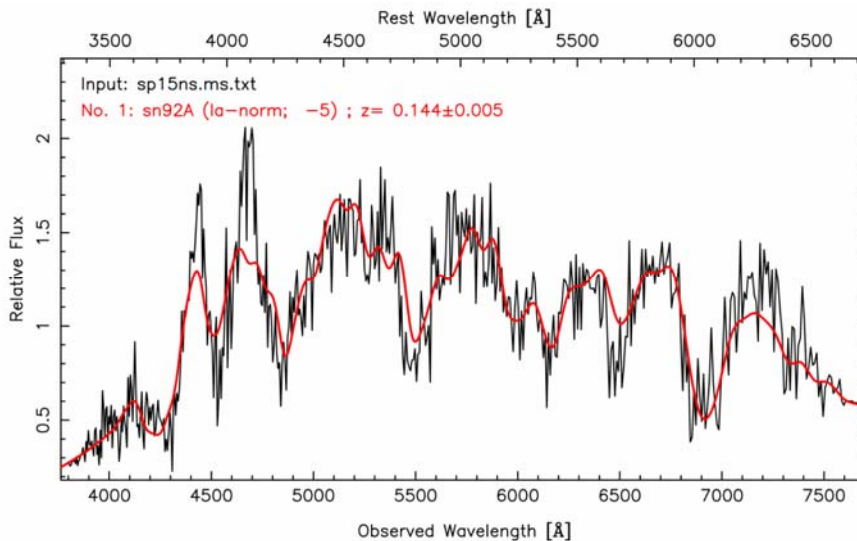

*Espectre de la supernova SN2007ph, a un desplaçament al roig de  $z=0.144$ , pres el 5 de novembre de 2007 al TNG. Podem veure superimposat l'espectre d'una supernova estàndard del tipus Ia, desplaçat a  $z=0.144$ , observada cinc dies abans de produir-se la màxima emissió de llum.*

## El Projecte PAU (Physics of the Accelerating Universe)

El projecte PAU (de les sigles en anglès de Física de l'Univers Accelerat) va començar en el context del programa Consolider Ingenio 2010 del MEC (Ministeri d'Educació i Ciència). Va ser aprovat per cinc anys amb un finançament de 5 M€, començant a l'octubre del 2007. D'acord amb els objectius del Consolider, el projecte ha estat presentat amb la voluntat de liderar un experiment significatiu a

Espanya, en aquest cas en l'àrea del cosmologia observacional. A més de l'IFAE, que és la institució coordinadora, hi ha altres sis institucions d'Espanya a PAU: CIEMAT (Madrid), IAA (Granada), ICE-CSIC (Barcelona), IFT-UAM (Madrid), IFIC-UV (València) i PIC (Barcelona). Els membres de l'IFAE a PAU són: Laia Cardiel, Enrique Fernández (coordinador del Projecte PAU), Josep Antoni Grífols, Eduard Massó i Ramon Miquel.

El projecte PAU persegueix diversos objectius. Un d'ells és el d'estudiar l'energia fosca des del punt de vista de la física teòrica, implicant a físics teòrics de partícules, físics experimentals i astrònoms. Un altre objectiu és portar a terme activitats educatives i de difusió cap a societat en general. Un altre objectiu, i el més substancial en termes de recursos, és la construcció d'un instrument consistent en una càmera de CCDs amb un camp molt ample ( 6 graus<sup>2</sup>) per a la mesura fotomètrica del desplaçament cap al vermell de galàxies, basat en una gran nombre de filtres de banda estreta, i en la preparació d'un cartografiat de galàxies amb aquest instrument situat en un telescopi de classe 2m, cobrint una regió d'uns 8000 graus<sup>2</sup>. El més probable és que el telescopi sigui una nova instal·lació dedicada inicialment a aquest propòsit.

L'objectiu científic principal del cartografiat és mesurar l'escala de BAO (oscil·lacions acústiques de barions) en funció del desplaçament cap al vermell. Les BAO tenen el seu origen en les fluctuacions de densitat creades per ones acústiques en el plasma de fotó-barions anterior a la recombinació, generades per perturbacions primordials. L'escala de BAO pot ser mesurada a partir d'un cartografiat extens. La posició angular i el desplaçament cap al vermell de galàxies dóna una mesura de la distribució de massa en tres dimensions. El senyal de BAO apareix com un pic en la funció de correlació de dos punts de la distribució de massa. De l'observació del fons de microones sabem l'escala de BAO, en concret  $r_{\text{BAO}} = 146.8 \pm 1.8$  Mpc per un univers pla del tipus  $\Lambda$ CDM.

A causa de la mida d'aquesta escala, la mesura de l'efecte requereix cartografiats extensos, d'aquí els 8000 graus<sup>2</sup> com a objectiu. Per altra banda l'ús d'una funció de correlació no requereix en principi mesures absolutes del flux. La majoria dels efectes sistemàtics tendeixen a augmentar l'amplària del pic però no la seva posició. Des d'aquest punt de vista BAO es considera un observable robust dels efectes de l'energia fosca. En tot cas, les incerteses sistemàtiques en BAO són diferents de les d'altres observables, el que afegix interès a la seva mesura.

La característica principal del cartografiat PAU és poder determinar fotomètricament desplaçaments cap al roig amb precisió suficient per a poder mesurar l'escala de BAO en funció d'aquesta

variable. L'alta precisió és possible utilitzant Galàxies Llumineses Roges (LRGs) com a indicadors de la distribució de massa a gran escala. Aquestes galàxies tenen un senyal característic en el seu espectre consistent en un salt en la lluminositat a una longitud d'ona d'aproximadament 4000Å en el sistema en repòs de la galàxia. L'ús d'un gran nombre (prop de 40) de filtres de banda estreta permet la determinació de la posició de discontinuïtat, permetent una precisió en la determinació del paràmetre de desplaçament cap al roig,  $z$ , de  $0.003 (1+z)$ , segons es desprèn de les simulacions. Amb el cartografiat esperem mesurar  $z$  per a més de deu milions d'aquestes galàxies, fins a  $z=0.9$ . L'escala de BAO en la direcció radial es relaciona directament amb el paràmetre de Hubble, proporcionant d'aquesta manera una mesura de la història de l'expansió de l'univers i per tant d'energia fosca.

Aquí solament hem considerat BAO, però les dades de PAU també podran donar informació sobre altres senyals sensibles a l'energia fosca. El cartografiat PAU també donarà desplaçaments cap al roig d'alta qualitat per a centenars de milions de galàxies de tota mena, la qual cosa contindrà informació molt valuosa de tipus astronòmic.

## Projectes de Raigs X

L'experiència de l'IFAE en el camp de les imatges digitals amb raigs X es remunta més de deu anys. Després de la conclusió exitosa del projecte FP5 "Detection of EARly MARKers in MAMmography" (DEAR-MAMA), l'IFAE, en col·laboració amb altres tres centres, Centre Nacional de Microelectrònica (CNM-IMB), UDIAT Centre Diagnòstic i EMSOR S.A., va començar un nou projecte per a desenvolupar un sistema de biòpsia mamària en 3D i temps real. Per a portar a terme el projecte es va adquirir una màquina de segona mà LoRad que ha estat modificada i ara treballa amb un detector de CdTe de 5cm x 5 cm amb un tamany de píxel de 100 micres. El nou disseny ofereix al doctor la possibilitat de veure l'agulla dintre de la mama en temps real durant el procediment i amb informació en 3D. Tot això facilita el treball del doctor i minimitza el malestar de la pacient.

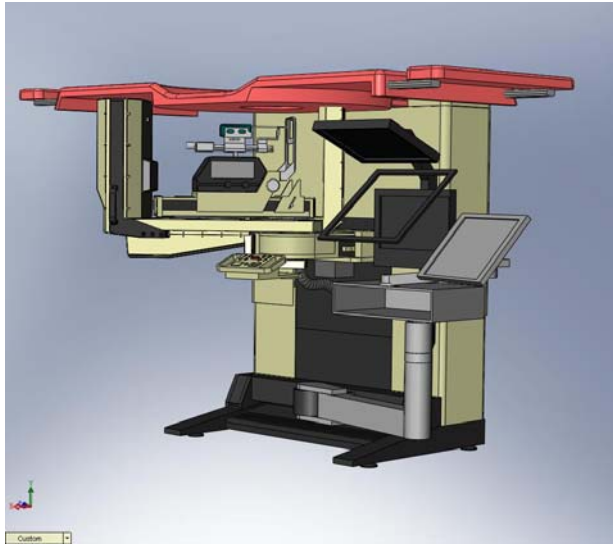

*Gràfic del nou sistema de biòpsia que estarà finalitzat a principis del 2008.*

A l'augmentar la quantitat d'informació oferta al doctor, aquest nou sistema permetrà reduir el temps del procediment des dels actuals 30-40 minuts fins a uns 10 minuts. També s'augmentarà l'índex d'èxit dels procediments (extracció correcta del teixit d'interès). En definitiva, la nova màquina de biòpsia ha estat dissenyada seguint els desitjos dels metges del centre diagnòstic UDIAT. Per tant vam pensar que molts metges voldran disposar d'un sistema com aquest.

En una altra àrea relacionada d'I+D, l'IFAE i el CNM han sol·licitat un projecte comú, liderat per l'IFAE, per a desenvolupar un innovador procés de "bump-bonding". El CNM desenvoluparà la tècnica de creixement de les boles de soldadura sobre els píxels del xip (ASIC)/detector, i l'IFAE es responsabilitzarà del procés de flip-xip. Per a concloure el projecte amb èxit, l'IFAE ha acordat una col·laboració amb X-Ray Imatek S.L. (empresa spin-off de l'IFAE) per a l'ús de la màquina de flip-xip Suss Microtec FC150, durant el transcurs del projecte. Aquesta màquina està considerada com una de les millors tant per a treballs d'I+D en el camp del bump-bonding com per a la seva producció en massa. La màquina va ser lliurada a l'estiu de 2007 i esperem tenir-la instal·lada i operativa en una sala blanca del CNM a principis de 2008. Ens agradaria emfatitzar el fet que aquesta màquina és única a Espanya amb aquesta qualitat i característiques. Aquesta màquina possibilita l'obertura de nous

camp d'investigació en la física d'altres energies a Espanya relacionats amb els detectors de píxels. L'objectiu d'aquest projecte és desenvolupar un procés eficient de bump-bonding fins a mides de píxels de fins a 50 micres.

A principis de 2007, IFAE va construir una sala emplomada que aconsegueix totes les normatives per a assegurar un ambient segur en la investigació amb raigs X. En aquesta sala han estat instal·lats també els diferents prototips construïts fins a la data.

L'empresa X-Ray Imatek S.L., creada en 2006 per a comercialitzar els resultats del DEAR-MAMA ha començat a funcionar amb el suport de l'òrgan de govern de l'IFAE i ha rebut ajuts del CDTI i el CIDEM. Per a més informació us podeu dirigir a la pàgina [www.xray-imatek.com](http://www.xray-imatek.com).

### **3.2 La Divisió de Teoria al 2007**

L'activitat de la Divisió de Teoria pot ser classificada en tres línies principals d'investigació: informació quàntica, física de les interaccions fonamentals i teoria d'astropartícules i cosmologia de partícules:

#### **Teoria de la informació quàntica**

La teoria de la informació quàntica fa ús de les lleis de la mecànica quàntica per al procesament de certes tasques computacionals que són absolutament impossibles de portar a terme en el marc de la física clàssica i els ordinadors moderns.

En 2007 hem treballat en diversos temes, entre els quals es troben: el problema de comunicar informació secreta a diversos receptors de tal forma que poden desxifrar el missatge actuant col·lectivament, i també a estendre el concepte de límit de Chernoff a la teoria quàntica.

#### **Física de les interaccions fonamentals**

Malgrat els seus èxits, hi ha moltes indicacions que el model estàndard (SM) no pot ser complet, perquè deixa moltes qüestions obertes sense resposta. És molt probable que els experiments en el LHC revelin

les respostes a algunes d'aquestes preguntes. El nostre grup es dedica a l'estudi de la física més enllà del SM en l'escala electrofeble. D'altra banda, les observacions que es realitzen en el LHC requereixen conèixer molts detalls de la física del sabor i de QCD. El nostre grup també treballa en aquesta empresa.

En 2007, en el camp del sabor i de la física QCD hem treballat, entre altres, en el problema del contingut gluònic dels mesons  $\eta$ ; en les recents mesures de  $B \rightarrow K^0 K^0$  i hem estudiat altres desintegracions del B; en les connexions entre el desenvolupament del producte d'operadors i models inspirats en QCD a gran  $N_C$ ; i en l'estudi d'alguns aspectes del desplaçament de Lamb. Quant a la física més enllà del model estàndard, hem estudiat el trencament de la simetria electrofeble en presència de sectors ocults, d'una banda, i en presència d'un bosó de Higgs que és un bosó pseudo-Goldstone per l'altra; les implicacions d'un Higgs compost, i alguns aspectes de l'estabilització del radió.

## **Teoria de astropartícules i cosmologia de partícules**

El nostre treball es caracteritza per l'estudi d'aspectes teòrics de la física de les partícules elementals i les seves interaccions, especialment en un ambient astrofísic o cosmològic. En aquests medis es verifiquen processos físics que estan suprimits en el laboratori, o bé es concreten d'altres maneres.

En 2007, hem treballat sobre els efectes en el fons còsmic de microones deguts a una gran curvatura abans d'inflació; en forces de llarg abast induïdes per una partícula escalar acoblada a fotons, i en les conseqüències fenomenològiques de forces leptòniques en les oscil·lacions de neutrins solars.

## 2. RESUMEN

Versió en Català a la pàgina 1

English version on page 21

En esta memoria se describen las actividades del Instituto de Física de Altas Energías (IFAE) en el año 2007.

### Estructura del IFAE

El IFAE es un consorcio entre la Generalidad de Cataluña y la Universidad Autónoma de Barcelona (UAB), creado el 16 de julio de 1991 por el Decreto 159/1991 del Gobierno de la Generalidad. En cuanto consorcio, el IFAE es una entidad legal con personalidad jurídica propia. La relación formal con la Generalidad se lleva a cabo a través del Departamento de Innovación, Universidad y Empresa (DIUE; anteriormente, DURSI).

El IFAE integra su propio personal con personal de los Grupos de Física Teórica y de Física de Altas Energías del Departamento de Física de la UAB; el Instituto incluye dos Divisiones, la Experimental y la Teórica. La lista del personal está en la página 33.

Los órganos de gobierno del Instituto son el Consejo de Gobierno y el Director. Las líneas generales de investigación, la contratación de personal, el presupuesto anual y la creación y la supresión de Divisiones son algunas de las responsabilidades del Consejo de Gobierno, el cual también designa al Director a partir de una lista de candidatos propuestos por el Rector de la UAB. El Director es responsable de la ejecución de las decisiones del Consejo de Gobierno. Los Coordinadores de las Divisiones son propuestos por el Director y designados por el Consejo de Gobierno. Los miembros del Consejo de Gobierno durante 2007 figuran en la página 32. El IFAE tiene también el estatuto de Instituto Universitario adscrito a la UAB, una fórmula que permite al personal del IFAE participar en el programa docente de la Universidad, en particular en los cursos doctorales.

En 2004 el IFAE se unió a sus instituciones fundacionales, la UAB y el DURSI, así como al CIEMAT (Centro de Investigaciones Energéticas y Medioambientales, un centro de investigación de carácter estatal con sede en Madrid), para crear y

promover el Puerto de Información Científica (PIC). Este centro, situado en el campus de la UAB, muy cerca del IFAE, tiene como objetivo dar apoyo a proyectos científicos que requieran el acceso distribuido a enormes cantidades de datos, tales como los futuros experimentos en el acelerador LHC del CERN. El IFAE ha sido encargado de la gestión administrativa del PIC por las otras instituciones firmantes del acuerdo. El PIC tiene su propio Director y Consejo de Gobierno. Las actividades del PIC están descritas en sus memorias.

### Objetivos de IFAE

Tal como figura en la Orden 159/1991 del Gobierno de la Generalidad de Cataluña, el objetivo del IFAE es realizar investigación y contribuir al desarrollo de la Física de las Altas Energías, tanto en su vertiente teórica como experimental.

Los orígenes del consorcio están en el Departamento de Física Teórica y en el Laboratorio de Física de Altas Energías (LFAE) de la UAB. El grupo teórico fue establecido en 1971, cuando se creó la universidad. El Laboratorio de Física de de Altas Energías fue creado en 1984, con el objetivo de iniciar la investigación en esta disciplina en la UAB, en particular para aprovechar de manera eficaz los retornos de la pertenencia al laboratorio internacional CERN, después de que España volvió a formar parte del mismo en 1982. Como se menciona en el Decreto 159/1991, la existencia del LFAE y de grupos de investigación teóricos en Cataluña, el deseo de reforzar la investigación en Física de Altas Energías, en particular en la vertiente experimental, y el deseo de colaborar en el esfuerzo del Gobierno español para desarrollar este campo, llevó a las autoridades de la Generalidad a crear el IFAE en 1991.

En los años siguientes la división experimental del IFAE pasó de 15 personas al personal actual consistente en aproximadamente 67 personas. El programa experimental se ha también ampliado, tanto en el número de proyectos como en su temática. En 1992 el grupo estaba involucrado en un solo experimento de física de partículas, denominado ALEPH, en el acelerador LEP del CERN, mientras que actualmente hay cuatro líneas distintas de investigación básica: física de partículas en colisionadores de hadrones, con ATLAS y CDF;

física de neutrinos, con K2K y T2K, astrofísica de altas energías, con los telescopios de MAGIC, y cosmología observacional, que inició en 2005 con el proyecto DES sobre energía oscura. Esta última línea se reforzó en 2007 con la aprobación de un proyecto Consolider-Ingenio 2010, liderado por el IFAE. Adicionalmente, hay una línea de investigación muy activa en física aplicada, enfocada en el desarrollo de nuevas técnicas de radiografía digital y de lectura de circuitos electrónicos de alta densidad. Además existe una colaboración muy estrecha con el PIC, en los aspectos computacionales de los experimentos del IFAE que ya producen o están a punto de producir datos.

La División Teórica ha ampliado también su programa de investigación desde que el IFAE fue creado. En la actualidad hay tres líneas principales de investigación: física de las interacciones fundamentales, astrofísica de altas energías e información cuántica.

El que el IFAE tenga personalidad jurídica propia le ha permitido asumir la gestión de sus propios proyectos así como de algunos proyectos externos.

Desde 1995 a 2001 el Laboratorio de Luz Sincrotrón (LLS) estuvo administrativamente dentro del IFAE. El LLS fue la organización que propuso la construcción de una Fuente de Luz de Sincrotrón en Barcelona, un proyecto aprobado tanto por el Gobierno central español como por el Gobierno de Cataluña en 2003. El sincrotrón está ahora en construcción.

El IFAE fue también la institución responsable de la construcción del edificio dedicado al funcionamiento de los telescopios de MAGIC en el Roque de los Muchachos en la Isla de La Palma; en la actualidad IFAE es la institución gestora del "Fondo Común" (los gastos de funcionamiento y operación) de la colaboración MAGIC.

Desde 1999 a 2004 el IFAE ha sido también la institución responsable del seguimiento, tanto técnico como administrativo, de un contrato entre el CERN y una empresa española, para la construcción de vasijas de vacío del imán toroidal del detector ATLAS, tal como se explica más adelante.

A continuación aparece una descripción muy breve de los proyectos de investigación del IFAE, en las Divisiones Experimental y Teórica. Las descripciones más detalladas se encuentran en el capítulo 7.

## 2.1 La División Experimental en 2007

En 2007, las actividades de la División Experimental se centraron en ocho proyectos, la mayoría de los cuales están en marcha desde años:

- ATLAS, un experimento de carácter general, en preparación para el Large Hadron Collider del CERN, el Centro Europeo de Física de Partículas, que arrancará en 2008;
- CDF, un experimento de colisiones antiprotón-protón que se lleva a cabo en Laboratorio Nacional Fermi (FNAL), en Illinois, EE. UU.;
- T2K, un experimento de interacciones de neutrinos situado en Japón que se pondrá en marcha en 2009; además, se está estudiando un posible experimento situado en el Laboratorio Subterráneo de Canfranc (Husca).
- MAGIC, un experimento de astrofísica de rayos gamma que está tomando datos en las Islas Canarias; MAGIC terminará la construcción de un segundo telescopio Cherenkov en 2008;
- CTA, un conjunto de muchos telescopios Cherenkov, actualmente en fase de diseño.
- DES (Dark Energy Survey), construyendo un telescopio para observar unos 300 millones de galaxias en el hemisferio sur, para estudios de cosmología;
- PAU (Physics of the Accelerating Universe), una colaboración española que se formó con el apoyo de un proyecto Consolider-Ingenio 2010; PAU se dedicará a estudios de cosmología a partir de observaciones del cielo del hemisferio norte con un nuevo telescopio, que se construirá en Aragón;
- Nuevas técnicas de radiografía digital y de lectura de semiconductores de gran densidad, aprovechando los resultados de DearMama, un proyecto del IFAE financiado por la Unión Europea que desarrolló una cámara digital de rayos-X de alta resolución y contraste y con una dosis de radiación al paciente muy baja. Los estudios se llevan a cabo en colaboración con una empresa *spin-off* del IFAE, X-Ray Imatek.



## El Experimento ATLAS en el LHC del CERN

ATLAS es uno de los dos detectores del Large Hadron Collider (LHC), el acelerador construido en el CERN, donde colisionarán haces de protones con una energía total de 14 GeV, la mayor energía conseguida hasta el momento en un laboratorio. ATLAS investigará un amplio abanico de física, incluyendo la búsqueda del bosón de Higgs, de dimensiones extras, y de partículas candidatas a formar parte de la materia oscura.

El detector ATLAS es un aparato muy complejo, compuesto de varios subsistemas, y ha sido construido en muchos laboratorios en todo el mundo. En el momento actual más de 2100 científicos pertenecientes a 167 universidades y laboratorios de 37 países trabajan en el experimento ATLAS.

IFAE juega un papel muy importante en ATLAS. En nuestro instituto se construyó uno de los subdetectores más grandes de ATLAS, el calorímetro hadrónico o Tilecal (abreviatura de Tile Calorimeter). Este detector está formado por tres “barriles”, cada uno dividido en 64 módulos. En el año 2002 se terminó la producción en Barcelona de un barril completo (64 módulos de 12 toneladas cada

uno, más uno de recambio). IFAE también diseñó y fabricó la electrónica de calibración de Tilecal. Tilecal fue el primer detector instalado en la caverna del experimento ATLAS en el año 2005. Una vez instalado se efectuaron tests extensivos de la electrónica de los sistemas de lectura y calibración, en los cuales IFAE jugó, y aún juega, un papel muy importante.

Además del trabajo en el detector, IFAE está muy involucrado en otros aspectos del experimento ATLAS, como son:

- a) Contribuciones al sistema de “trigger” de ATLAS, en particular a la infraestructura del Filtro de Sucesos, operaciones y tareas de integración del trigger y estudios de nivel-1 y nivel-2 de trigger.
- b) Programa de física de ATLAS: preparación de los análisis que buscan física nueva mediante el estudio de posibles procesos de ruido, utilizando datos simulados.
- c) Infraestructura de cálculo: administración y funcionamiento de un centro Tier 2 y un centro Tier 3.
- d) Participación en la gestión de ATLAS.

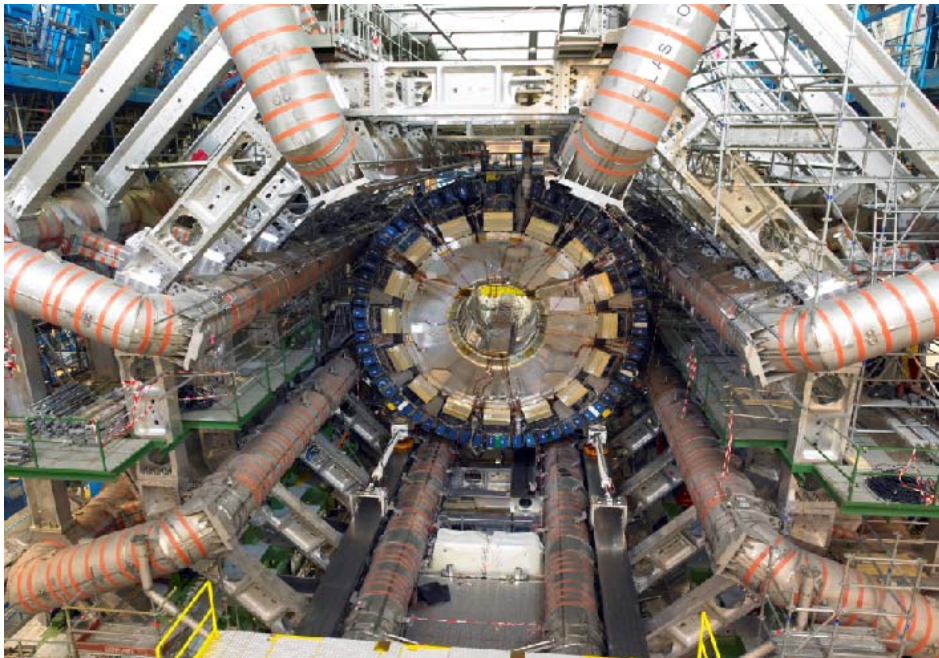

*Vista del calorímetro en su posición final, juntamente con los imanes toroidales*

## CDF (Collider Detector at Fermilab)

Con el fin de prepararse para los análisis de física del LHC, en 2003 un grupo de científicos del IFAE decidió participar en el experimento CDF en el colisionador Tevatron (Fermi National Accelerator Laboratory, EEUU), donde se producen colisiones entre protones y antiprotones con una energía en el centro de masas de 2 TeV. El experimento CDF descubrió el quark top en 1995 y desde el año 2001 toma de nuevo datos con un detector altamente mejorado.

El programa de física del Tevatron y del LHC son similares y hasta la puesta en marcha del LHC en otoño de 2008 el Tevatron se mantiene como el acelerador con más energía en el mundo. El incremento de luminosidad del acelerador ha permitido medidas de precisión y puede dar lugar al descubrimiento de nueva física en el futuro.

Desde 2003, el grupo de IFAE en CDF ha tomado la responsabilidad del control de calidad de los datos del experimento (DQM). El grupo del IFAE también juega un papel líder en el análisis de los datos con jets de hadrones en el estado final, así como en la búsqueda de supersimetría (SUSY) en CDF. Durante 2007, el grupo ha consolidado aun más si cabe su presencia dentro de CDF y miembros del grupo actúan como coordinadores de los grupos de QCD, SUSY y Operaciones del Detector.

En 2007, el grupo de IFAE publicó nuevos resultados de secciones eficaces de producción inclusiva de jets, Phys. Rev. D75, 092006 (2007). El grupo también completó un estudio de la producción de jets en sucesos con un bosón Z en el estado final, estudio que fue enviado para su publicación en 2007 y recientemente publicado en Phys. Rev. Lett. 100, 102001 (2008). Además, se obtuvieron resultados finales de la búsqueda inclusiva de squarks y gluinos en SUSY. Los resultados han mejorado sensiblemente los límites actuales en las masas de dichas partículas, y se encuentran en el proceso de publicación.

La fuerza del grupo quedó de nuevo demostrada en 2007 con 13 comunicaciones en conferencias y workshops, incluyendo una charla plenaria en la

conferencia Lepton-Photon en Korea, considerada la más importante en el campo de la física de partículas en 2007.

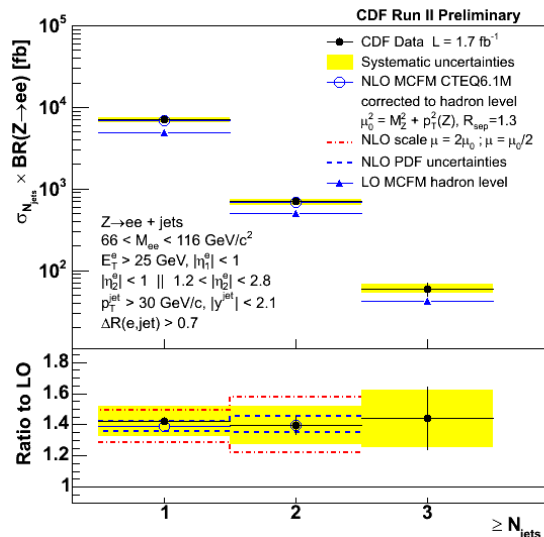

Sección eficaz de producción de sucesos Z+jets

Dos estudiantes del grupo defendieron sus tesis doctorales en primavera del 2007 y continúan sus carreras científicas con posiciones post-doctorales en universidades de primera categoría en USA y Alemania.

En estrecha colaboración con el PIC, el grupo de IFAE en CDF mantiene el cluster de ordenadores BCNAF, fundamental para los proyectos de análisis del grupo, y que ha sido usado para la producción masiva de sucesos simulados por parte de CDF. En 2007, la capacidad de la granja se incremento un 20% y ha mantenido una ocupación de casi el 100%.

## Experimentos de Neutrinos

K2K es un experimento de oscilaciones de neutrinos en el cual un haz de neutrinos producido en el laboratorio KEK en la costa este de Japón es enviado a la mina de Kamioka a 250 km de distancia en la costa oeste de Japón. Los neutrinos atraviesan la tierra sin apenas interaccionar. El experimento mide el flujo de neutrinos de tipo muón después del punto de producción en el laboratorio KEK y en la mina Kamioka. Para ello dos detectors son operados, uno a 200 m del punto de producción y otro lejano, llamado Super-Kamiokande, en la mina Kamioka,

consistente en un tanque de 50.000 toneladas de agua ultra-pura. El flujo se mide detectando el número de las interacciones de neutrinos del tipo corriente cargada cuasi-elástica. Las medidas del detector cercano se usan para predecir el número de interacciones en el detector lejano que se compara con las medidas que allí se realizan. Un déficit en este número es una indicación del fenómeno conocido como oscilaciones de neutrinos. El año 2007 fue el último en que el IFAE mantuvo una actividad significativa en este experimento que terminó la toma de datos en el año 2004.

El IFAE está involucrado en la segunda generación de estos experimentos de oscilaciones denominado T2K. La principal diferencia es que la intensidad del haz de neutrinos que se planea que aumente un factor 20. Para ello se usará un nuevo acelerador en construcción en el laboratorio JPARC también en la costa este de Japón y a una distancia de 300 km de Kamioka a donde se envía el haz de neutrinos. El grupo del IFAE se ha concentrado en el detector cercano que será un espectrómetro localizado a 280 metros del punto de producción de los neutrinos. El detector está siendo diseñado para optimizar las sensibilidades con respecto de aquel usado en K2K, para ello se planea usar un imán de gran tamaño pero baja intensidad (0.2 T). Las partículas cargadas que se producen en las interacciones de neutrinos son detectadas en un detector denominado cámara de proyección temporal (o Time Projection Chamber, TPC).

El objetivo del experimento T2K es la medida de la transición de neutrinos de tipo muón a otros de tipo electrón lo que aporta información sobre los parámetros que gobiernan las oscilaciones. El experimento tiene grandes aportaciones de instituciones japonesas, europeas y norteamericanas. El IFAE ha contribuido de forma significativa al diseño y a la producción y caracterización de los detectores que se están produciendo. Un prototipo del detector final fue probado al final del año 2007 mostrando un comportamiento excelente en las condiciones nominales de uso.

El primer prototipo completo de la TPC se construirá durante el año 2008 y será instalado para su operación durante el año 2009 coincidiendo con el primer haz de neutrinos.

El IFAE comenzó a evaluar en el año 2006 la posibilidad de contribuir a la construcción y operación de un experimento para el Laboratorio Subterráneo de Canfranc (LSC) en el Pirineo oscense. El laboratorio está a unos 1000 metros de profundidad lo que minimiza el flujo de rayos cósmicos, que son una fuente de ruido en experimentos de baja radioactividad. Estas son unas condiciones excepcionales para la realización de experimentos llamados de desintegración doble beta. Este proceso nuclear es muy raro, sus vidas medias pasan de los  $10^{20}$  años, pero aporta información fundamental sobre la naturaleza última de los neutrinos. El IFAE, junto con otras instituciones españolas, ha propuesto un experimento de desintegración doble beta basado en una TPC de Xenón gaseoso a alta presión enriquecido en un isótopo que es un candidato a emisor doble beta.

## Los Telescopios MAGIC

MAGIC es el acrónimo de Major Atmospheric Gamma-Ray Imaging Telescope (Gran Telescopio de Imagen de Cherenkov Atmosférico). El telescopio está situado en el Observatorio del Roque de los Muchachos en La Palma (Islas Canarias). Su objetivo es el estudio de los rayos gamma de muy alta energía que llegan a la Tierra de un número relativamente pequeño de fuentes. Estos nos dan información sobre los mecanismos que producen tal radiación, que figuran entre los más violentos conocidos en el cosmos. Por otra parte la propagación de la radiación en distancias cosmológicas es sensible a la geometría y al contenido de materia del cosmos en sí mismo. MAGIC observa la luz inducida por las interacciones de los rayos gamma entrantes en la parte superior de la atmósfera. Esta luz es reflejada en un espejo segmentado de 17 m de diámetro y es recogida por la cámara, localizada en el foco. La cámara contiene fotodetectores muy rápidos y sensibles.

El grupo del IFAE construyó en su totalidad la cámara del telescopio y su sistema de control, así como el edificio que aloja la electrónica y los equipos de toma de datos. Además es responsable del control general del telescopio.

El telescopio comenzó su operación regular en 2004. En 2007 se entró en el tercer ciclo de observaciones. Durante el año se han publicado 11 artículos en revistas, muchos de los cuales han sido iniciados por los físicos del IFAE, o han recibido contribuciones importantes de ellos, y se ha completado una tesis doctoral.

Resumiendo, lo más destacado de las observaciones de 2007 en las que ha estado directamente implicado el instituto:

- observación del resto de supernova Cas A y descubrimiento de la fuente de origen desconocido MAGIC J0616+225;
- descubrimiento del primer agujero negro de masa estelar que emite rayos gamma de muy alta energía, Cygnus X-1;
- observación de numerosos Núcleos Galácticos Activos (AGN), incluyendo el descubrimiento de 1ES 1011+496, a un corrimiento al rojo elevado,  $z=0.212$ ;
- se observó variación muy rápida, en la escala de minutos, durante un destello de Mrk 501 y se descubrió una correlación entre la energía de los rayos gamma y sus tiempos de llegada, fenómeno que se espera si hay ruptura de la invariancia de Lorentz debida a fenómenos de Gravedad Cuántica. Los resultados de MAGIC ponen límites estrictos a estas teorías;
- límites superiores a la emisión gamma de galaxias “starburst” y de Explosiones de Rayos Gamma (GRB).

En 2005 la colaboración comenzó la construcción de un segundo telescopio, MAGIC-II, que será un clon técnicamente mejorado del original MAGIC-I. MAGIC-II está situado a unos 100 m del anterior, y observará en coincidencia con MAGIC-I. Esta operación en “estéreo” permitirá mejorar las resoluciones espectral y angular, así como la supresión del ruido, incrementando la sensibilidad en un factor dos, y contribuirá a reducir el umbral de observación en energía.

MAGIC-II utiliza nuevos fotosensores y una electrónica de digitalización más rápida (con muestras a 2-4 GHz). El telescopio se pondrá en marcha en septiembre de 2008. Durante 2007 se ha completado la fase de diseño y prototipado. El IFAE es responsable del sistema de recepción de señales

analógicas por fibra óptica, co-responsable de la lectura y adquisición de datos, responsable del sistema de control de los dos telescopios, y organiza la instalación y puesta en marcha del centro de datos del sistema de dos telescopios.

## **El Proyecto CTA (Cherenkov Telescope Array)**

CTA (“Cherenkov Telescope Array”) será una instalación avanzada para la astronomía de rayos gamma de muy alta energía desde tierra basada en la observación de radiación Cherenkov. Se cimienta en el liderazgo mundial y la experiencia en la técnica del “Imaging Atmospheric Cherenkov Telescope” desarrollada por las instalaciones H.E.S.S. y MAGIC. CTA será un observatorio muy grande, con decenas de Telescopios Cherenkov desplegados en un observatorio en el hemisferio norte y otro en el sur y un coste estimado de unos 150 M€. En este momento CTA está en fase de estudio de diseño y participan en él unos 300 científicos europeos.

IFAE ha participado activamente en la emergencia del proyecto y en la creación de la colaboración CTA, y es también muy visible en este momento su participación en el estudio de diseño.

## **El Proyecto “Dark Energy Survey” (DES)**

En 2011, el proyecto internacional Dark Energy Survey (DES), liderado por Fermilab (EEUU), comenzará a cartografiar 5000 grados cuadrados del cielo galáctico desde el hemisferio sur, midiendo las posiciones en el cielo, las formas y los “redshifts” (corrimientos al rojo) de cerca de 300 millones de galaxias y 15000 cúmulos de galaxias. Además, se observarán repetidamente otros 10 grados cuadrados de cielo con el objetivo de medir las magnitudes y “redshifts” de más de 1000 supernovas (SNe) lejanas de tipo-Ia. Estas mediciones permitirán realizar estudios detallados de las propiedades de la llamada “energía oscura”, responsable de la actual expansión acelerada del universo.

Para realizar el cartografiado, la Colaboración DES está construyendo una cámara de CCDs (DECam) de gran campo que irá montada en el foco principal del

telescopio Blanco de 4 metros, situado en Cerro Tololo en Chile. El IFAE, junto al Institut de Ciències de l'Espai (ICE) y el CIEMAT, construirá toda la electrónica de lectura de los CCDs de la DECam, a la vez que diseñará tres de las cuatro principales placas. Durante 2007, el diseño de las placas en el IFAE se desarrolló al ritmo esperado, llegándose a producir una primera versión de la Tarjeta de Transición y un diseño inicial de la Placa Madre de Control.

En paralelo al diseño de las placas de la electrónica, se trasladó un dispositivo de pruebas de la electrónica del ICE a IFAE, y fue completamente automatizado y caracterizado, produciéndose mapas de intensidad de luz cada 5 nm en longitud de onda, entre 300 y 1200 nm. Una vez caracterizado, el sistema puede ser utilizado para estudiar las propiedades de los CCDs de DES. El sistema ha sido probado testeando CCDs más pequeños, sub-productos de la producción de DES. Las pruebas incluyen exposiciones de los CCDs tanto a luz

visible como a rayos X provenientes de una fuente de Americio 241, lo cual permite una medida absoluta de la eficiencia en la transferencia de carga del CCD.

Con el fin de prepararse para el análisis de datos de supernovas de DES, algunos miembros del IFAE, ICE y CIEMAT se unieron en 2007 al programa de observación espectroscópica de las SNe del proyecto "Sloan Digital Sky Survey (SDSS-II)", en un rango de corrimiento al rojo entre 0.1 y 0.4. El grupo del IFAE lideró una propuesta para el "Telescopio Nazionale Galileo" (TNG) en La Palma que obtuvo cuatro noches de observaciones en 2007. Las observaciones tuvieron como resultado los espectros de 25 objetos, 9 de los cuales resultaron ser SNe tipo-Ia, incluyendo uno extremadamente peculiar, SN2007qd, y 4 fueron SNe del tipo II. Se informó acerca de estas observaciones en tres circulares del CBET.

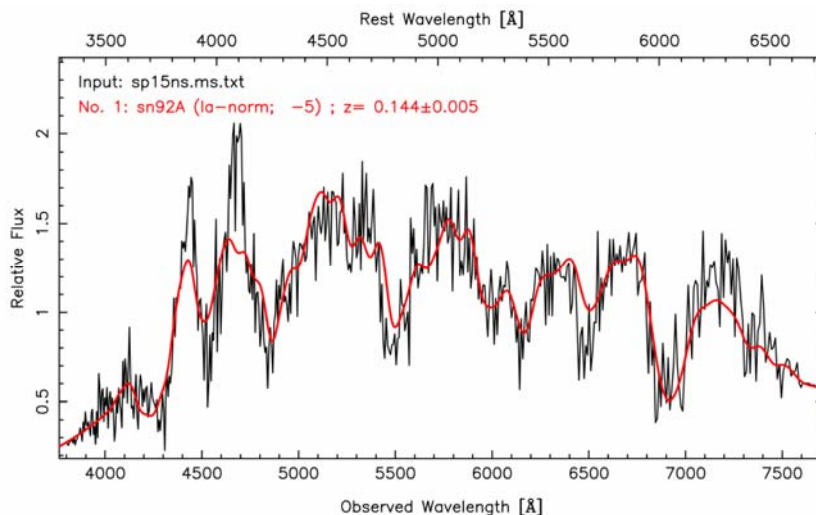

*Espectro de la supernova SN2007ph, ( $z=0.144$ ), obtenido el 5 de Noviembre de 2007 con el TNG. Puede verse superpuesto un espectro de una supernova estándar de tipo Ia, desplazado a  $z=0.144$ , observada cinco días antes del máximo de luz.*

## El Proyecto PAU (Physics of the Accelerating Universe)

El proyecto PAU (de las siglas en inglés de Física del Universo Acelerado) fue comenzado en el contexto del programa Consolider-Ingenio 2010 del MEC (Ministerio de Educación y Ciencia). El proyecto ha sido aprobado por cinco años con una

financiación de 5 M€, comenzando en octubre del 2007. En consonancia con los objetivos del Consolider, el proyecto fue presentado con la voluntad de liderar un experimento significativo en España, en este caso en el área de cosmología observacional. Además del IFAE, que es la institución coordinadora, hay otras seis instituciones españolas en PAU, a saber, CIEMAT (Madrid), IAA

(Granada), ICE-IEEC (Barcelona), IFT-UAM (Madrid), IFIC-UV (Valencia) y PIC (Barcelona). Los miembros de IFAE en PAU son: Laia Cardiel, Enrique Fernández (coordinador del Proyecto PAU), Josep Antoni Grifols, Eduard Massó y Ramon Miquel.

Dentro de PAU hay varios objetivos. Uno de ellos es el de estudiar la energía oscura desde el punto de vista de la física teórica, implicando a físicos teóricos de partículas, físicos experimentales y astrónomos. Otro objetivo es llevar a cabo actividades educativas y de difusión hacia la sociedad en general. Otro objetivo, y el más substancial en términos de recursos, es la construcción de un instrumento consistente en una cámara de CCD con un campo muy amplio ( $\sim 6$  grados<sup>2</sup>) para la medida fotométrica del corrimiento al rojo de galaxias, basado en una gran número de filtros de banda estrecha, y la preparación de un cartografiado de galaxias con dicho instrumento, cubriendo una región de unos 8000 grados<sup>2</sup>, instalado en un telescopio de clase 2 m. Lo más probable es que el telescopio sea una nueva instalación, dedicada a este proyecto inicialmente.

El objetivo científico principal del cartografiado es medir la escala de BAO (oscilaciones acústicas de bariones) en función del corrimiento al rojo. Las BAO tienen su origen en las fluctuaciones de densidad creadas por ondas acústicas en el plasma de fotón-bariones anterior a la recombinación, generadas por perturbaciones primordiales. La escala de BAO puede ser medida a partir de un cartografiado extenso. La posición angular y el corrimiento al rojo de galaxias da una medida de la distribución de masa en tres dimensiones. La señal de BAO aparece como un pico en la función de correlación de dos puntos de la distribución de masa. De la observación del fondo de microondas sabemos la escala de BAO, en concreto  $r_{\text{BAO}} = 146.8 \pm 1.8$  Mpc para un universo plano del tipo  $\Lambda$ CDM.

Debido a lo grande de la escala, la medida del efecto requiere cartografiados extensos, de ahí el objetivo de 8000 grados<sup>2</sup>. Por otra parte el uso de una función de correlación no requiere en principio medidas absolutas del flujo. La mayoría de los efectos sistemáticos tienden a aumentar la anchura del pico pero no su posición. Desde este punto de vista BAO se considera un observable robusto de los efectos de

la energía oscura. En todo caso, las incertidumbres sistemáticas en BAO son diferentes de las de otros observables, lo que añade interés a su medida.

La característica principal del cartografiado PAU es poder determinar fotométricamente corrimientos al rojo con precisión suficiente para poder medir la escala de BAO en función de esta variable. La alta precisión es posible utilizando Galaxias Luminosas Rojas (LRGs) como indicadores de la distribución de masa a gran escala. Estas galaxias tienen una señal característica en su espectro consistente en un salto en la luminosidad a una longitud de onda de aproximadamente 4000 Å en el sistema en reposo de la galaxia. El uso de un gran número (cerca de 40) de filtros de banda estrecha permite la determinación de la posición de la discontinuidad, permitiendo una precisión en la determinación del parámetro de corrimiento al rojo,  $z$ , de  $0.003 (1+z)$ , según se desprende de las simulaciones. Con el cartografiado esperamos medir  $z$  para más de diez millones de estas galaxias, hasta  $z=0.9$ . La escala de BAO en la dirección radial se relaciona directamente con el parámetro de Hubble, proporcionando de esta manera una medida de la historia de la expansión del universo y por lo tanto de la energía oscura.

Aquí hemos considerado solamente BAO, pero los datos de PAU también podrán dar información sobre otras señales sensibles a la energía oscura. El cartografiado PAU también dará corrimientos al rojo de alta calidad para millones de galaxias de todo tipo, lo cual contendrá información muy valiosa de tipo astronómico.

## Proyectos de Rayos X

La experiencia del IFAE en el campo de las imágenes digitales con rayos X se remonta a hace más de diez años. Después de la conclusión exitosa del proyecto FP5 “Detection of EARly MARKers in MAMmography” (DEAR-MAMA), IFAE en colaboración con otros tres centros: Centro Nacional de Microelectrónica (CNM-IMB), UDIAT Centro Diagnóstico y EMSOR S.A. empezaron un nuevo proyecto para desarrollar un sistema de biopsia mamaria en 3D y tiempo real. Para llevar a cabo el proyecto se adquirió una máquina de segunda mano LoRad que ha sido modificada y ahora trabaja con

un detector de CdTe de 5 cm x 5 cm con un tamaño de píxel de 100 micras. El nuevo diseño ofrece al doctor la posibilidad de ver la aguja dentro de la mama en tiempo real durante el procedimiento y con información en 3D. Todo ello facilita el trabajo del doctor y minimiza el malestar de la paciente.

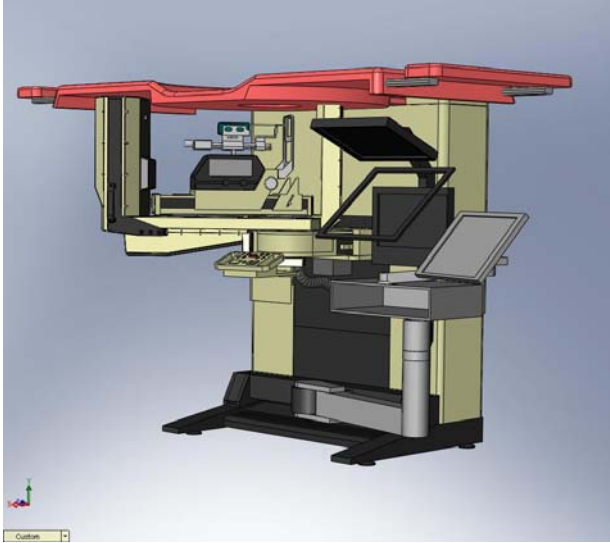

*Gráfico del nuevo sistema de biopsia que estará finalizado a principios de 2008.*

Al aumentar la cantidad de información ofrecida al doctor, este nuevo sistema permitirá reducir el tiempo del procedimiento desde los actuales 30-40 minutos hasta unos 10 minutos. También se aumentará el índice de éxito de los procedimientos (extracción correcta del tejido de interés). En definitiva, la nueva máquina de biopsia ha sido diseñada siguiendo los deseos de los médicos de centro diagnóstico UDIAT. Por lo tanto pensamos que muchos médicos querrán disponer de un sistema como éste.

En otra área relacionada de I+D, IFAE y CNM han solicitado un proyecto común, liderado por el IFAE, para desarrollar un innovador proceso de “bump-bonding”. CNM desarrollará la técnica de crecimiento de las bolas de soldadura sobre los píxeles del chip (ASIC)/detector, y el IFAE se responsabilizará del proceso de “flip-chip”. Para concluir el proyecto con éxito, el IFAE ha sellado una colaboración con X-Ray Imatek S.L. (empresa spin-off del IFAE) para el uso de la máquina de flip-chip Suss Microtec FC150, durante el transcurso del proyecto. Esta máquina está considerada como una

de las mejores tanto para trabajos de I+D en el campo del bump-bonding como para su producción en masa. La máquina fue entregada en el verano de 2007 y esperamos tenerla instalada y operativa en una sala blanca del CNM para principios de 2008. Nos gustaría enfatizar el hecho de que esta máquina es única en España con su calidad y características. Esta máquina posibilita la apertura de nuevos campos de investigación en la física de altas energías en España relacionados con los detectores de píxeles. El objetivo de este proyecto es desarrollar un proceso eficiente de bump-bonding hasta tamaños de píxeles de hasta 50 micras.

A principios de 2007, IFAE construyó una sala emplomada que cumple todas las normativas para asegurar un ambiente seguro en la investigación con rayos X. En esta sala han sido instalados también los distintos prototipos construidos hasta la fecha.

La empresa X-Ray Imatek S.L., creada en 2006 para comercializar los resultados de DEAR-MAMA ha comenzado a funcionar con el apoyo del órgano de gobierno del IFAE y ha recibido ayuda del CDTI y el CIDEM. Para más información se pueden dirigir a la página [www.xray-imatek.com](http://www.xray-imatek.com).

## **3.2 La División de Teoría en 2007**

La actividad de la División de Teoría puede ser clasificada en tres líneas principales de investigación: información cuántica, física de las interacciones fundamentales y teoría de astropartículas y cosmología de partículas:

### **Teoría de la información cuántica**

La teoría de la información cuántica hace uso de las leyes de la mecánica cuántica para el proceso de ciertas tareas computacionales que son absolutamente imposibles de llevar a cabo en el marco de la física clásica y los computadores modernos.

En 2007 hemos trabajado en varios temas, entre los cuales destacan: el problema de comunicar información secreta a varios receptores de tal forma que pueden descifrar el mensaje actuando colectivamente, y extender el concepto de límite de Chernoff a la teoría cuántica.

## **Física de las interacciones fundamentales**

A pesar de sus éxitos, hay muchas indicaciones que el modelo estándar (SM) no puede ser completo, porque deja muchas cuestiones abiertas sin respuesta. Es muy probable que los experimentos en el LHC revelen las respuestas a algunas de estas preguntas. Nuestro grupo se dedica al estudio de la física mas allá del SM en la escala electrodébil. Por otro lado, las observaciones que se realizarán en el LHC requieren conocer muchos detalles de la física del sabor y de QCD. Nuestro grupo también trabaja en esta empresa.

En 2007, en el campo del sabor y de la física QCD hemos trabajado, entre otros, en el problema del contenido gluónico de los mesones  $\eta$ ; en las recientes medidas de  $B \rightarrow K^0 K^0$  y hemos estudiado otras desintegraciones del B; en la conexión entre el desarrollo del producto de operadores y modelos inspirados en QCD a gran  $N_c$ ; y en el estudio de algunos aspectos del corrimiento de Lamb. En cuanto a la física mas allá del modelo estándar hemos estudiado la rotura de la simetría electrodébil en presencia de sectores ocultos, por un lado, y en presencia de un bosón de Higgs que es un bosón pseudo-Goldstone por la otra ; las implicaciones de un Higgs compuesto, y algunos aspectos de la estabilización del radión.

## **Teoría de astropartículas y cosmología de partículas**

Nuestro trabajo se caracteriza por el estudio de aspectos teóricos de la física de las partículas elementales y sus interacciones, especialmente en un ambiente astrofísico o cosmológico. En estos medios se verifican procesos físicos que están suprimidos en el laboratorio, o bien se concretan de otras maneras.

En 2007, hemos trabajado sobre los efectos en el fondo cósmico de microondas debidos a una gran curvatura antes de inflación; en fuerzas de largo alcance inducidas por una partícula escalar acoplada a fotones, y en las consecuencias fenomenológicas de fuerzas leptónicas en las oscilaciones de neutrinos solares.



### 3. SUMMARY

Versió en Català a la pàgina 1

Versión en Castellano en la página 11

This report covers the activities of the High Energy Physics Institute of Barcelona (Institut de Física d'Altes Energies, IFAE) during 2007.

#### IFAE Structure

The IFAE is a consortium between the Generalitat de Catalunya (the Government of the Autonomous Region of Catalonia) and the Universitat Autònoma de Barcelona (UAB). It was formally created on July 16, 1991, by Act number 159/1991 of the Generalitat. As a Consortium the IFAE is a legal entity with its own independent legal status. Functionally it depends from the Department of Innovation, Universities and Industries (DIUE; formerly, DURSI) of the Generalitat.

The IFAE complements its own staff with that of the Theoretical and Experimental High Energy Physics Groups of the Department of Physics of the UAB; it is comprised of the Experimental and Theoretical Divisions. The personnel of the two divisions is listed at page 33 of this report.

The executive bodies of the Institute are the Governing Board (Consell de Govern) and the Director. The general lines of activity, the hiring of personnel, the annual budget and the creation and suppression of Divisions are among the responsibilities of the Governing Board, which also appoints the Director from a list of candidates nominated by the Rector of UAB. The Director is responsible for the execution of the decisions of the Governing Board. The Coordinators of the Divisions are nominated by the Director and appointed by the Governing Board. The members of the Governing Board during 2007 are listed at page 32.

IFAE also has the status of a "University Institute" attached to UAB. This formula allows the personnel of IFAE to participate in the educational programme of UAB, in particular in giving doctoral courses.

In 2004 IFAE joined its parents institutions, the UAB and DURSI, as well as CIEMAT (Center for

Research in Energy and Environment Sciences, a national research organization based in Madrid) to create and promote the Scientific Information Port (Port d'Informació Científica, PIC). This center, located on the UAB campus very close to IFAE, aims at supporting projects that require distributed access to large amounts of data, such as the future experiments at the LHC facility of CERN. The IFAE was charged by the other partner institutions with administrating this Center. PIC has its own Director and Governing Board. The activities of PIC are described in its own reports.

#### IFAE Goals

As stated in the foundational Act 159/1991 of the Generalitat, the mission of IFAE is to carry out research and to contribute to the development of both theoretical and experimental High Energy Physics.

The origins of the consortium date back to the Department of Theoretical Physics and to the Laboratory for High Energy Physics (LFAE) of UAB. The theoretical group was established in 1971, when the university was founded. The Laboratory for High Energy Physics was created in 1984, in order to start research in experimental high-energy physics at UAB, particularly to use effectively the facilities of CERN, after Spain joined again CERN in 1982. As mentioned in Act 159/1991, the existence of LFAE and of theoretical research groups in Catalonia, the desire to strengthen research in High Energy Physics, particularly on the experimental side, and the desire to collaborate with the Spanish Government's efforts to develop this field, led the authorities of the Generalitat to create the IFAE in 1991.

In the following years the experimental division of IFAE grew from a staff of 15 to about 67 at present. The experimental program has also expanded both in the number of projects and in their scope. In 1992 the group was involved in just one experiment in high energy particle physics, ALEPH at LEP, while at present there are four different lines of basic research: particle physics at hadron colliders with ATLAS and CDF, neutrino physics, with K2K and T2K, particle astrophysics, with the MAGIC telescopes, and observational cosmology, established

in 2005 with the DES (Dark Energy Survey) project. This latter line was strengthened in 2007 by the approval of a Consolider-Ingenio 2010 project, led by IFAE. In addition to these activities, there is a small but well-established line of applied physics, active in digital radiography and in high-density semiconductor readout techniques. There is a very close collaboration with PIC on the computational side of all IFAE experiments that are producing data or will do so in the near future.

The Theoretical Division also expanded its research program since the IFAE was created. There are at present three main lines of research: physics of the fundamental interactions, astroparticle physics and quantum information.

The fact that the IFAE is an independent legal entity allows it to manage its own projects as well as certain external ones.

From 1995 to 2001 the Synchrotron Light Laboratory of Barcelona (LLS) was administratively part of IFAE. The LLS was the organization that proposed and prepared the construction of ALBA, the Synchrotron Light Laboratory, currently being built very close to the UAB in Barcelona. The project was jointly approved in 2003 by the Spanish Government in Madrid and the Catalan Government.

The IFAE was also the institution responsible for the construction of the building that services the MAGIC telescopes at the Roque de los Muchachos site in the Island of La Palma; IFAE now manages the Common Fund (maintenance and operation funds) of the MAGIC collaboration.

From 1999 to 2004 the IFAE also provided technical and administrative management of the contract between CERN and a Spanish company for the construction of the vacuum vessels of the ATLAS Barrel Toroid, as described further below.

Very brief descriptions of the research projects of IFAE's Experimental and Theoretical Divisions are given in this section. Full reports are given in chapter 7 of this document.

### 3.1 The Experimental Division in 2007

During 2007 the Experimental Division's activities focused on eight projects:

- ATLAS, a general-purpose experimental facility in preparation for the Large Hadron Collider of CERN, the European Center for Particle Physics, which will begin operation in 2008;
- CDF, a proton-antiproton collider experiment taking place at the Fermi National Accelerator Lab in USA;
- T2K, a neutrino long base-line experiment taking place in Japan, that will begin taking data in 2009; in addition, a possible experiment to be sited in the Canfranc underground laboratory is under study;
- MAGIC, an experiment in gamma-ray astrophysics and astroparticle physics at the Canary Islands, being upgraded with a second Cherenkov telescope;
- CTA, a very large array of Cherenkov telescopes, currently in the design stage;
- DES (Dark Energy Survey), which is building a telescope to observe about 300 million galaxies visible from the Southern Hemisphere, for cosmology studies;
- PAU (Physics of the Accelerating Universe), a Spanish collaboration formed under the auspices of a Consolider project, that will perform cosmology studies by observing the Northern sky with a new telescope, that will be built in Aragon;
- novel digital radiography techniques and new dense readout technologies, capitalizing on the results of DearMama, an EU-funded project that developed a digital X-ray camera of high resolution and contrast with very small exposure of the patient to radiation. These studies are carried out in collaboration with an IFAE spin-off company, X-Ray Imatek.

## The ATLAS Experiment at CERN's LHC

ATLAS is one of the two general-purpose detectors at the Large Hadron collider (LHC), the accelerator built at CERN, in which protons will be made to collide against protons with a total energy of 14 TeV, the highest ever achieved in a laboratory. It will investigate a wide range of physics, including the search for the Higgs boson, extra dimensions, and particles that could make up dark matter.

The ATLAS detector is a very complex apparatus, made up of several subsystems, built on dozens of laboratories around the world. At present more than 2100 scientists from 167 universities and laboratories in 37 countries work on the ATLAS experiment.

IFAE is a major player in ATLAS. Our institute was a focal point in the assembly of one of the largest of the ATLAS sub-detectors, the Hadron Calorimeter, or Tilecal (short for Tile Calorimeter). This sub-detector consists of three "barrels", each made of 64 modules. In 2002 the IFAE completed the production in Barcelona of one complete barrel (64

modules, each weighting 12 tons, plus 1 spare). IFAE also designed and fabricated the Tilecal calibration electronics. Tilecal was the first detector installed in the cavern of the ATLAS experiment, in 2005. Once in place, extensive tests of the electronic readout systems and of the calibration were carried out, in which IFAE had and still has a major role

In addition to the work on the detector, IFAE is heavily involved in other aspects of the ATLAS experiment, among them:

- a) Contributions to the ATLAS trigger system, in particular to the Event Filter Infrastructure, Trigger Operations and Integrations Tasks and Level-1 and Level-2 Trigger Studies.
- b) ATLAS physics program: preparations of analyses of "discovery physics" by studying possible backgrounds to them using simulated data.
- c) Computing infrastructure: operation of a Tier-2 and a Tier-3 centres.
- d) Participation in the management of ATLAS.

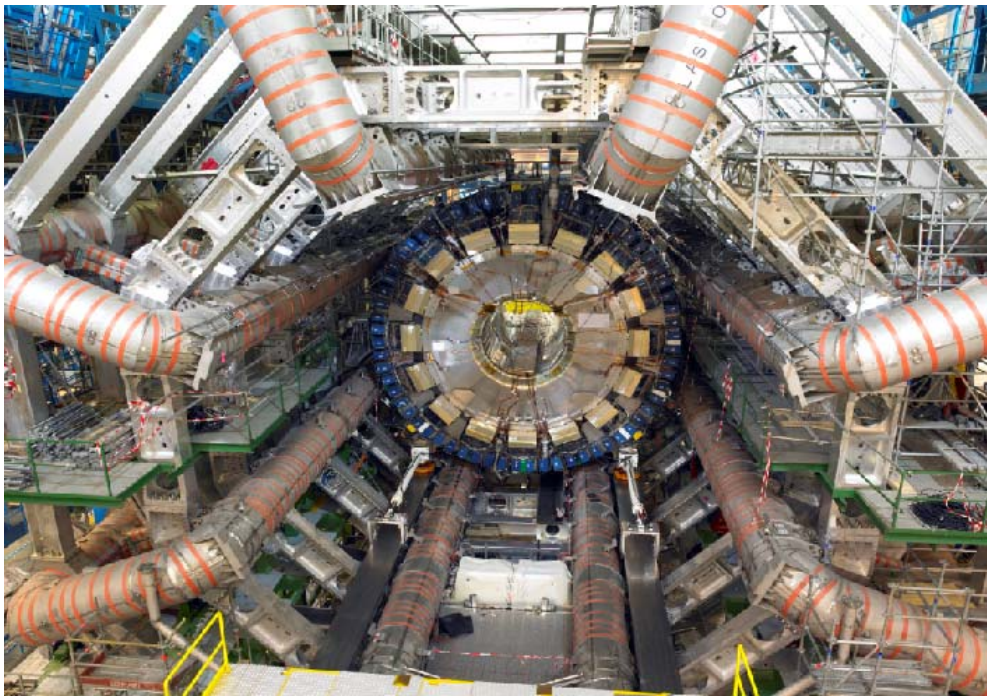

*View of the barrel calorimeter in its final position, and the barrel toroid magnets.*

## The Collider Detector at the Tevatron (CDF)

In preparation for the physics analyses at the LHC, in 2003 IFAE joined the CDF experiment, which is, in many ways, a forerunner of ATLAS. It takes place at the Tevatron Collider of the Fermi National Accelerator Laboratory of the U.S.A., in Illinois. In the Tevatron, two 1 TeV proton and antiproton beams collide head-on, giving a total centre of mass energy of 2 TeV. CDF has been running since the early nineties and has produced many important results, among them the discovery of the top quark in 1995. An important upgrade of the collider and of CDF has been in full swing since the beginning of the decade.

The physics goals are similar to those of the LHC, although the lower energy of the beams may not allow reaching the scale at which new phenomena are manifest. Nevertheless, the higher luminosities will provide important measurements in the future and may lead to discoveries, while the Tevatron remains the highest-energy accelerator laboratory in the world.

Since 2003, the IFAE group in CDF has taken major responsibilities in the quality control of the data taken by the experiment (DQM). The IFAE group has also played a leading role in physics analysis involving jets of hadrons as well as in searches for signal of supersymmetry in CDF. In 2007, the group further consolidated its position within CDF, and members of the IFAE team acted as QCD physics convener, SUSY physics convener, and CDF Detector Operations Manager.

During 2007, the IFAE group in CDF published additional results on inclusive jet production, Phys. Rev. D 75, 092006 (2007). The group also completed a study on jet production in events with a Z boson in the final state that was submitted for publication in 2007 and recently published in Phys. Rev. Lett. 100, 102001 (2008). In addition, final results on the search for squark and gluinos in supersymmetry – one of the preferred theoretical scenarios for new phenomena – were obtained, which significantly expanded the limits on the masses and are about to be submitted for publication.

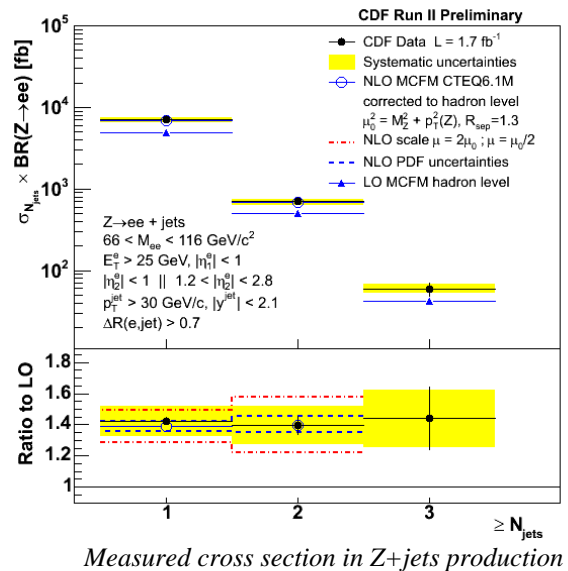

The strength of the group in physics analyses was again demonstrated in 2007 with 13 communications in workshops and conferences, including a plenary talk at the Lepton-Photon conference in Korea, considered the most important international conference in the field.

Two PhD students from the group defended their theses in spring of 2007 and now continue their scientific careers with first-class research associate positions in USA and Germany.

In close collaboration with the PIC, the IFAE-CDF group maintained its computer farm which has been instrumental to the IFAE analysis projects and is used for massive simulations by the entire collaboration. In 2007, the farm capacity was increased by 20% and has reached an almost 100% occupancy.

## Neutrino Experiments

The K2K neutrino oscillation experiment is a long-baseline experiment in which a beam of neutrinos, produced in the KEK laboratory in Japan, is sent to the Kamioka mine, located 250 km away. The neutrinos travel through the earth with negligible attenuation. The experiment measures the flux of

muon-type neutrinos at two different locations: near the KEK laboratory, where they are produced, and 250 km away at the Kamioka mine in western Japan. For this purpose, the experiment has two detectors: a near detector placed 200 m downstream of the neutrino production target, and a far detector in Kamioka, the Super-Kamiokande detector, consisting of a huge tank (50,000 tons) of very pure water. The flux is measured by counting the number of quasi-elastic muon-neutrino interactions in a given fiducial volume of the two detectors. The measurements at the near detector are extrapolated to the far detector and compared with what is actually measured there. 2007 was the last year of activities in K2K, mainly on studies of neutrino-nucleus interactions, while moving to new experiments.

The IFAE group is also involved in a second-generation long-baseline neutrino experiment, T2K. Here, a much more intense beam of neutrinos, from the new accelerator JPARC being built in Tokai, Japan, will be sent to Super-Kamiokande, 300 km away. The IFAE group's efforts focus on the near detector, a spectrometer at 280 m from the neutrino production target. It will use a large, low-field magnet (0.2 T). The charged particles will be detected by a Time-Projection Chamber (TPC).

The main goal of this experiment is to measure the muon-neutrino to electron-neutrino transition rate, which will give information on a still unknown parameter of the oscillations. This experiment has been approved by the Japanese authorities and has a large participation from European groups. IFAE contributed extensively to the detector design studies, and to the detector production and performance evaluation tests. The prototypes of this detector have been tested with cosmic rays in the TPC of the HARP experiment, at CERN in 2007 under nominal conditions with very good results.

The first prototype of the full T2K TPC will be built and operated during 2008, in view of having the entire detector installed at Tokai in 2009.

The IFAE group is also involved in a possible experiment to be carried out in the new experimental hall of the Canfranc underground laboratory (LSC). The depth of the laboratory – which minimizes the backgrounds from cosmic rays – and the available surface area present exciting opportunities to

perform at the LSC a next-generation experiment on neutrino-less double-beta decay. These exceedingly rare nuclear process, if conclusively detected, would give a very fundamental result on the nature of neutrinos. IFAE together with other Spanish institutions has proposed a neutrino-less double beta decay experiment based on a pressurized Time Projection Chamber filled with gaseous Xenon enriched in an isotope that is a double beta emitter.

## The MAGIC Telescopes

MAGIC is the acronym of Major Atmospheric Gamma-ray Imaging Telescope. The telescope is located at the Roque de los Muchachos Observatory in the Island of La Palma of the Canary Islands (28.8N, 17.9W, 2200 m altitude). The objective of the experiments is the study of the very high energy gamma radiation arriving to Earth from a relatively small number of sources. This study gives information on the mechanisms that produce such radiation, the most violent known in the cosmos. Furthermore the propagation of the radiation over cosmological distances is sensitive to the geometry and matter contents of the cosmos itself. MAGIC detects the light induced by the interactions of the incoming gamma rays with the upper atmosphere. This light is reflected onto a segmented mirror of 17m diameter and collected in the camera, located at the focal point. The camera is provided with very fast and sensitive photo-detectors.

The IFAE group built the camera of the telescope and its control system, as well as the building housing the electronics and data taking equipment. In addition IFAE is in charge of the overall control of the telescope.

The telescope started regular operation in 2004 and entered its third cycle of observations in 2007. Along the year 11 journal articles were published. IFAE has initiated or taken a leading role in many of them. A PhD thesis was completed during this year.

Follows a summary of the publications which IFAE has been mainly involved in:

- observation of the supernova remnant Cas A and discovery of MAGIC J0616+225, a source of unknown origin;

-discovery of the first stellar-mass black hole which emits gamma rays, Cygnus X-1;

-observation of numerous Active Galactic Nuclei, including the discovery of IES 1011+496, at a high redshift  $z=0.212$ ;

-observation of very fast variability, in time scales of minutes, during a flare of Mrk 501; a correlation was established between the gamma ray energy and its arrival time, a phenomenon which is expected if Lorentz invariance is violated due to Quantum Gravity effects. The results of MAGIC set stringent upper limits on these theories;

-upper bounds to the gamma ray emission of starburst galaxies and the prompt emission of Gamma Ray Bursts.

In 2005 the collaboration began the construction of a second telescope, MAGIC-II, which is a technically improved clone of the original MAGIC-I. MAGIC-II is located 100 m away from MAGIC-I and will observe in coincidence. This “stereo” operation will allow improved spectral and angular resolutions, increase the sensitivity by a factor two and reduce the energy threshold.

MAGIC is equipped with more sensitive photosensors and faster sampling digitization (2-4 GHz). The telescope will start operations in September 2008. The design and prototyping phase was completed in 2007. IFAE is responsible for the optical reception of the camera analog signals, co-responsible for the readout and data acquisition, responsible for the central control of the two telescope system and organizes the installation and set up of the data center for the two telescopes.

## **The CTA (Cherenkov Telescope Array) Project**

CTA (“Cherenkov Telescope Array”) will be an advanced facility for ground based very-high-energy gamma ray astronomy, based on the observation of Cherenkov radiation. It builds on the worldwide leadership and the mastering of the Imaging Atmospheric Cherenkov Telescope technique developed by the H.E.S.S. and MAGIC installations. CTA will be a very large observatory with tens of Cherenkov telescopes deployed in a site on the north and a site on the south hemispheres and a total price

tag of about 150 M€. Currently CTA is in a design study phase that involves around 300 European scientists.

IFAE has actively participated in the emergence of the CTA project and the creation of the CTA collaboration and is now very visibly participating in the CTA design study as well.

## **The Dark Energy Survey (DES) Project**

Starting in 2011, the Dark Energy Survey (DES) international project, led by Fermilab (USA), will survey 5000 sq. deg. of the southern galactic sky, measuring positions on the sky, shapes and redshifts of about 300 million galaxies and 15000 galaxy clusters. Furthermore, another 10 sq. deg. of the sky will be repeatedly monitored with the goal of measuring magnitudes and redshifts of over 1000 distant type-Ia supernovae (SNe). These measurements will allow detailed studies of the properties of the so-called “dark energy” that drives the current accelerated expansion of the universe.

To perform the survey, the DES Collaboration is building a large wide-field CCD camera (DECam) to be mounted at the prime focus of the 4-meter Blanco Telescope, located in Cerro Tololo in Chile. IFAE, together with Institut de Ciències de l’Espai (ICE) and CIEMAT, will build the whole set of read-out electronics boards of DECam, while designing three out of the four main boards. During 2007 board design at IFAE proceeded at the expected pace, producing a first working version of the Transition Board and an initial design of the Master Control Board.

In parallel to the electronics board design, a CCD and electronics test set-up was moved from ICE to IFAE, and was fully automated and characterized; producing light intensity maps every 5 nm in wavelength, from 300 to 1200 nm. Once characterized, the system can be used to study properties of DES CCDs. The system has been exercised by testing smaller CCDs that are by-products of the DES production runs. The tests include exposing the CCDs to both visible light and X-rays from an Americium 241 source, which

permits an absolute measurement of the CCD charge-transfer efficiency.

In preparation for the analysis of DES supernova data, some members of IFAE, ICE and CIEMAT joined in 2007 the program of spectroscopic follow-up of the supernovae found in the Sloan Digital Sky Survey (SDSS-II) project, in a redshift range

between 0.1 and 0.4. The IFAE group led a proposal to the “Telescopio Nazionale Galileo” (TNG) in La Palma that was awarded four nights of observations in 2007. The observations resulted in spectra of 25 objects, out of which nine turned out to be type-Ia SNe, including an extremely peculiar one, SN2007qd, and four were type-II SNe. The observations were reported in three CBET circulars.

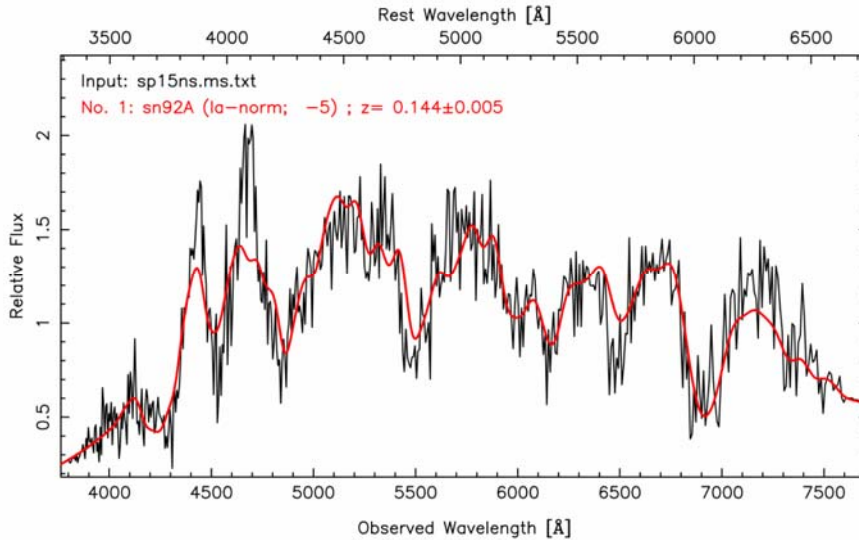

*Spectrum of supernova SN2007ph, at redshift  $z=0.144$ , taken on November 5<sup>th</sup> 2007 at TNG. Superimposed is a template of a standard type-Ia supernova redshifted to  $z=0.144$ , observed five days before maximum light.*

## The PAU (Physics of the Accelerating Universe) Project

The PAU (Physics of the Accelerating Universe) project was started in the context of the Consolider-Ingenio 2010 Program of the MEC (Spanish Ministry of Education and Science). It was approved for five years with a grant of 5 M€, starting in October of 2007. Consistent with the Consolider goals, the project was submitted with the aim of leading a significant experiment in Spain, in this case in the area of observational cosmology. In addition to the IFAE, which is the coordinating institution, there are other six institutions from Spain in PAU, namely, CIEMAT (Madrid), IAA (Granada), ICE-IEEC (Barcelona), IFT-UAM (Madrid), IFIC-UV (Valencia) and PIC (Barcelona). The members of IFAE in PAU are: Laia Cardiel, Enrique Fernández (PAU overall Coordinator),

Josep Antoni Grifols, Eduard Massó and Ramon Miquel.

There are several distinct objectives within PAU. One of them is to study dark energy from the theoretical physics point of view, involving particle theorists, experimentalists and astronomers. Another is to carry out educational and outreach activities towards society in general. Yet another objective, and the most substantial in terms of resources, is to construct an instrument consisting of a very wide-field CCD camera ( $\sim 6 \text{ deg}^2$ ) for galaxy photometric red-shift measurements based on a large number of narrow-band filters, and to prepare a large galaxy survey, of about  $8000 \text{ deg}^2$ , with such an instrument installed in a 2 meter class telescope. Most likely the telescope will be a new facility, initially dedicated to this task.

The main scientific objective of the survey is to measure the scale of BAO (Baryon Acoustic Oscillations) as a function of red-shift. BAO have their origin in the density fluctuations created by acoustic waves in the photon-baryon plasma before recombination, generated by primordial perturbations. The BAO scale can be determined from a galaxy survey. The angular position and red-shift of galaxies give a measurement of the clustering of mass in three dimensions. The BAO signature will show up as a peak in the two-point correlation function of the mass distribution. From the observation of the CMB we know the scale of BAO, namely  $r_{\text{BAO}} = 146.8 \pm 1.8$  Mpc comoving, for a flat  $\Lambda$ CDM universe.

Because of the large scale of the effect, its measurement requires very large surveys and that is the reason for the  $8000 \text{ deg}^2$ . On the other hand the use of a correlation function does not require in principle absolute flux measurements. Most systematic effects tend to increase the width of the peak but not its position. From this point of view BAO is supposed to be a robust observable for dark energy. In any case, the systematic uncertainties in BAO are different from those of other observables, giving an extra interest to the measurement.

The main characteristic of the PAU survey is to be able to photometrically determine redshifts with enough precision to be able to measure the scale of BAO as a function of this variable. The high precision is possible by targeting Luminous Red Galaxies (LRGs) as tracers of mass. These galaxies have a characteristic break in their spectrum at approximately  $4000 \text{ \AA}$  rest frame. The use of a large number (about 40) of narrow band filters allows the determination of the position of this break, giving a precision in the red-shift parameter  $z$  of  $0.003(1+z)$ , according to simulations. We expect to measure red-shifts of over ten million of these galaxies up to  $z=0.9$ . The scale of BAO in the radial direction is related directly to the Hubble parameter, providing a sensitive probe of the history of the expansion rate and therefore of dark energy.

Here we have only considered BAO, but the PAU data will also contain information on other probes of dark energy. The survey will also give high-quality red-shifts for millions of galaxies, providing a wealth of astronomical information.

## The X-Ray Projects

The experience of IFAE in the field of digital X-ray imaging goes back for more than a decade. After the successful conclusion of the FP5 project “Detection of Early Marker in Mammography”, known as Dear-Mama, IFAE, in collaboration with other three institutes, Centro Nacional de Microelectrónica (CNM-IMB), UDIAT Centre Diagnostic, and EMSOR S.A. started the development of a 3D real-time breast biopsy machine (patent pending). To realize the project we have acquired a second hand LoRad biopsy machine which has been converted to a state-of-the-art biopsy machine. It has a provisional CdTe sensor detector of  $5 \text{ cm} \times 5 \text{ cm}$ , with spatial resolution of 100 microns. The medical doctor can see the position of the needle inside the breast in real time and can see as well the exact position of the needle’s tip with respect to the target tissue (potential cancerous tissues), with utmost clarity, thanks to the 3D view provided by this biopsy machine.

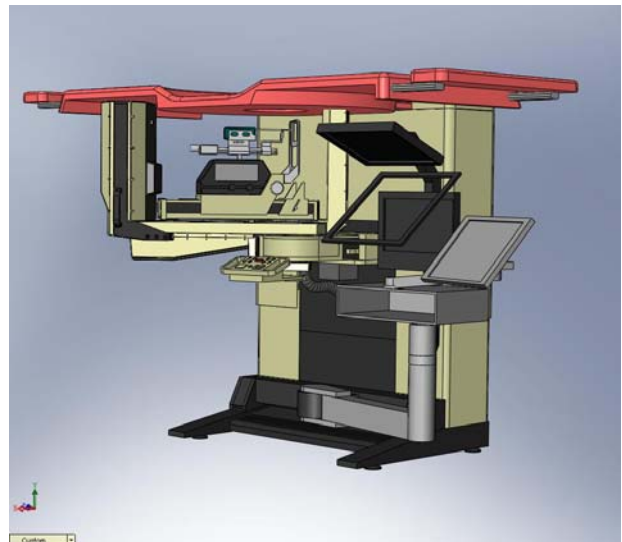

*CAD presentation of the 3D breast biopsy machine, which will be ready in early 2008.*

Both the patient and the doctor will benefit from such a biopsy machine since it will reduce the time of operation (and the trauma for the patient) significantly from 30-40 minutes to around 10 minutes, and makes the intervention a success from the first attempt. In summary, the 3D biopsy machine has been designed to meet the wishes of the



doctors at UDIAT centre diagnostic and hence we believe that many doctors performing a breast biopsy intervention will wish to have a machine like this.

On a related R&D, IFAE and CNM applied for a coordinated project, led by IFAE, to develop the bump-bonding process. CNM will develop the growth of the solder bumps on the pixel electrodes of ASIC/detector, and IFAE will do the flip-chip process. To achieve this goal, IFAE has formed a collaboration with X-ray Imatek SL (an IFAE spin-off) to use its flip-chip machine, Suss Microtec FC150, for the duration of the R&D. This flip-chip machine is considered one of the best flip-chip machines for R&D on bump-bonding processes and also for production line. The machine was delivered in summer 2007 and it is expected to be installed in the CNM clean room in early 2008. It is important to emphasise that the FC150 machine is a unique machine of its type and performance in Spain. This machine will open wide the scope of research of the HEP community in Spain in the field of pixel detectors. The aim of this R&D is to develop a reliable bump-bonding processing for various room temperature solid state detectors with pixel pitch as small as 50 microns.

In early 2007, IFAE built a dedicated lead-shielded room, matching hospital specifications, to secure a safe infrastructure for the R&D activities related to X-ray digital sensors and also to host all the X-ray machines that have been developed under the leadership of IFAE.

The spin-off company X-ray Imatek SL, created in 2006 to exploit the results of Dear-Mama project, has started its activities on the premises of IFAE with the support of the IFAE governing board. The scope and the profile of the spin-off were highly evaluated by both CDTI and CIDEM. More about the spin-off can be found at [www.xray-imatek.com](http://www.xray-imatek.com)

### 3.2 The Theory Division in 2007

The activities of the Theory Division can be classified into three main research lines: quantum information, the physics of fundamental interactions and astroparticle and particle cosmology:

#### Quantum Information Theory

Quantum Information Theory employs the laws of quantum mechanics for the efficient processing of certain computational tasks that are intractable within classical physics and modern computers.

In 2007 we have worked in a variety of subjects including: the problem of communicating intrinsic information secretly to multiple recipients in such a way that they can unveil the secret message only if they act collectively, and also extending the concept of Chernoff bound to quantum theory.

#### Physics of the Fundamental Interactions

Despite its successes, there are many indications that the standard model (SM) of particle interactions cannot be complete, because it leaves many questions without any answer. It is very likely that experiments at the LHC will reveal some of the answers to these questions. Our group is devoted to study physics beyond the SM at the electroweak scale. Also the future observations at LHC require the knowledge of many details related to flavor physics and QCD. Our group also works in such endeavor.

In 2007, in the field of flavor and QCD physics we have, among other subjects, worked in the problem of the gluonic content of the  $\eta$  mesons, exploited the recent measurements of  $B \rightarrow K^0 K^0$  and studied other B-decays; studied the connection between operator product expansion and large  $N_c$ -inspired QCD models; studied some aspects of the Lamb shift. In physics beyond the SM we have studied electroweak symmetry breaking in the presence of hidden sectors, on the one hand, and in the presence of a pseudo-Goldstone boson Higgs on the other; and also we have investigated the implications of having a composite Higgs, as well as some aspects of the stabilization of the radion.

#### Theoretical Astroparticle and Particle Cosmology

The general goal of our work in this field is the study of some of the theoretical issues in the physics

of elementary particles and their interactions when they happen in an astrophysical or cosmological medium.

In 2007, we have worked on the effects on the Cosmic Microwave Background coming from a large curvature before inflation; on the long-range forces induced by a scalar particle coupled to photons; and on the phenomenological implications of leptonic forces in solar neutrino oscillation.

## 4. ABOUT IFAE

---

### 4.1 Structure

The Institut de Física d'Altes Energies (IFAE) is a Consortium between the Generalitat de Catalunya and the Universitat Autònoma de Barcelona (UAB). It was formally created on July 16, 1991, by Act number 159/1991 of the Government of Catalonia (Generalitat de Catalunya). As a Consortium the IFAE is a legal entity with its own "juridical personality". Functionally it depends from the Department of Innovation, Universities and Enterprises (DIUE, formerly DURSI) of the Generalitat.

The governing bodies of the Institute are the Governing Board (Consell de Govern) and the Director. The general lines of activity, the hiring of personnel, the annual budget and the creation and suppression of Divisions are among the responsibilities of the Governing Board, which also appoints the Director from a list of candidates nominated by the Rector of UAB. The Director is responsible for the execution of the decisions of the Governing Board. The Coordinators of the Divisions are nominated by the Director and appointed by the Governing Board.

IFAE integrates its own personnel with personnel of the Theoretical and Experimental High Energy Physics Groups of the Department of Physics of the UAB. Personnel of the Departments of Structure and Fundamental Constituents of Matter and of Fundamental Physics of UB were also members of the IFAE by means of the agreement between the Institute and UB established in 1992. This agreement was modified in 2003. Under the new terms, the cooperation between the IFAE and the UB is focused on specific goal-oriented projects.

The IFAE is structured in two Divisions: Experimental and Theoretical. The Theory Division of the IFAE is formed by most of the members of the theory group of the Physics Department of the UAB. All the personnel of the Experimental Division is from IFAE itself or from the UAB.

The IFAE has also the status of a "University Institute" attached to UAB. This formula allows the personnel of IFAE to participate in the educational programme of UAB, in particular by giving doctoral courses.

### 4.2 IFAE goals

As stated in the foundational Act 159/1991 of the Generalitat, the goal of the IFAE is to carry out research and to contribute to the development of both theoretical and experimental High Energy Physics.

The origins of the consortium are in the Department of Theoretical Physics and in the Laboratory for High Energy Physics (LFAE) of UAB. The theoretical group was established in 1971, when the university was founded. The Laboratory for High Energy Physics was created in 1984, in order to start research in experimental high-energy physics at the UAB, particularly to use effectively the CERN laboratory, after Spain rejoined the CERN organization in 1982. As mentioned in Act 159/1991 the existence of LFAE and of theoretical research groups in Catalonia, the desire to strengthen research in High Energy Physics, particularly in the experimental side, and the desire to collaborate in the Spanish Government effort to develop this field, led the authorities of the Generalitat to create the IFAE.

In the following years the experimental division of IFAE grew from a staff of 15 to about 67 at present. The experimental program has expanded both in the number of projects and in their scope. In 1992 the group was involved in just one experiment in high energy particle physics, ALEPH at LEP, while at present there are four different lines of fundamental research: particle physics at hadron colliders, neutrino physics, gamma-ray astrophysics, and observational cosmology. In addition, there is a small but well-established line of applied physics, devoted to novel techniques in digital radiography.

The Theoretical Division also expanded its research program since the IFAE was created. There are at present three main lines of research: physics of the fundamental interactions, astroparticle physics and quantum information.

An additional important development took place in 2003, driven by the strongly perceived need for remote handling of vast quantities of scientific data, not only for High-Energy physics experiments but also for astrophysical - facilities such as MAGIC. In 2003 three Spanish institutions, the UAB, the CIEMAT in Madrid and the Departament d'Universitats Recerca i Societat de la Informació (DURSI, now DIUE) of the Government of Catalonia, together with IFAE, jointly founded the Port of Scientific Information (PIC). This center aims at being a focal point of the global computing grid for scientific projects requiring the processing of large amounts of data. PIC was chosen by the Spanish Ministry of Science and Education as a Tier-1 center for LHC computing. IFAE has been charged by the other partner institutions with the administration of PIC. The scientific activities of PIC are described in its own reports. There is a very close collaboration with PIC on the computational side of all IFAE experiments that are producing data or will do so in the near future.

It is worth to emphasize that as an independent legal entity IFAE can manage its own projects as well as certain external ones. These management activities have been a very visible contribution of IFAE to the development of scientific infrastructures, which might not have been possible otherwise. The most important among these activities are briefly recalled next.

From 1995 to 2001 the Synchrotron Light Laboratory of Barcelona (LLS) was administratively part of IFAE. The LLS was the organization that proposed and prepared the construction of ALBA, the Synchrotron Light Laboratory, currently being built very close to the UAB in Barcelona. The project was jointly approved in 2003 by the Spanish Government in Madrid and the Catalan Government.

The IFAE was also the institution responsible for the construction of the building that services the MAGIC telescopes at the Roque de los Muchachos site in the Island of La Palma; IFAE now manages

the Common Fund (maintenance and operation funds) of the MAGIC collaboration.

From 1999 to 2004 the IFAE also provided technical and administrative management of the contract between CERN and a Spanish company for the construction of the vacuum vessels of the ATLAS Barrel Toroid. This was a major project, with a cost of about 3 million euro distributed over several years.

### 4.3 IFAE Governing Board

<b>GOVERNING BOARD</b>
<b>President</b>
Blanca Palmada Félez, Commissioner for Universities and Research , D.I.U.E.
<b>Members</b>
Ramon Moreno Amich, Director General for Research, D.I.U.E
Jordi Marquet Cortés, Deputy Rector for Strategic Projects, U.A.B.
Ramon Pascual de Sans, Professor of Physics, U.A.B.
Joaquim Gomis Torné, Professor of Physics, U.B.

<b>DIRECTOR</b>
<b>Director</b>
Enrique Fernández, Professor of Physics, U.A.B.
<b>Theory Division Coordinator</b>
Eduard Massó, Associate Professor of Physics, U.A.B



## 5. IFAE PERSONNEL

IFAE complements its own staff (hired directly by the Institute) with personnel of the UAB. Below is a list of the members of the Experimental and Theory Divisions of IFAE during 2007.

### EXPERIMENTAL DIVISION

#### Faculty

Martine Bosman	Research Professor, IFAE
Pilar Casado	Adjunct Professor, UAB
Matteo Cavalli-Sforza	Research Professor, IFAE
Mokhtar Chmeissani	Research Professor, IFAE
Juan Cortina	Research Associate Professor, IFAE
José M. Crespo	Associate Professor, UAB
Manuel Delfino	Professor, UAB
Enrique Fernández	Professor, UAB
Ilya Korolkov	Research Associate Prof. (Ramón y Cajal), IFAE
Manel Martínez	Research Professor, IFAE
Mario Martínez	Research Professor, ICREA (Ramón y Cajal IFAE until 10/07)
Ramon Miquel	Research Professor, ICREA
Lluïsa Mir	Research Associate Professor, IFAE
Abelardo Moralejo	Research Associate Professor (Ramón y Cajal) IFAE
Cristóbal Padilla	Research Associate Professor, IFAE (on leave at CERN until 7/07)
Imma Riu	Research Associate Prof. (Ramón y Cajal), IFAE
Federico Sánchez	Research Associate Profesor, IFAE

#### Engineering Staff

Otger Ballester	Electronic Engineer, MAGIC/Neutrinos
Miquel Barceló	Electronic Engineer, MAGIC
Georges Blanchot (on leave at CERN)	Electronic Engineer, IFAE
Laia Cardiel	Electronic Engineer, IFAE
Ferran Grañena	Mechanical Engineer, IFAE
Jose M <sup>a</sup> . Illa	Electronic Engineer, MAGIC
Carles Puigdemgoles	Electronic Engineer, X-rays

## Scientific Post-docs

Alon Attal	CDF
Ulrike Blumenschein	ATLAS
Luca Fiorini	ATLAS
Thorsten Lux	Neutrinos
Marino Maiorino	X-Rays/DES
Daniel Mazin	MAGIC, since 2/07
Emma de Oña	MAGIC, until 2/07
Monica D'Onofrio	CDF, Postdoc Juan de la Cierva
Javier Rico	MAGIC, Postdoc Juan de la Cierva
Carlos Sánchez	X-rays
Sergei Sushkov	ATLAS, Postdoc Juan de la Cierva

## Computer Scientists and Engineers

Andreu Pacheco	IFAE/PIC, Senior Computing Engineer
Marc Campos	IFAE
Hegoi Garitaonandia	ATLAS (until 10/07)
Jaume Tomàs	IFAE

## Doctoral Students

José Alcaraz	Neutrinos (Scholarship MEC-FPI, IFAE)
Ester Aliu (until 6/07)	MAGIC (Project Contract, UAB)
Carolina Deluca	ATLAS (Scholarship Generalitat, IFAE)
Gianluca De Lorenzo (since 7/07)	ATLAS (Scholarship MEC-FPU, IFAE)
Manel Errando	MAGIC (Teaching Assistant, UAB)
Xavier Espinal (until 10/07)	Neutrinos (Project Contract, UAB)
Roger Firpo	MAGIC (Scholarship MEC-FPI, IFAE)
Lluís Galvany	DES (Project Contract, IFAE)
Sigrid Jorgensen (until 7/07)	ATLAS (Scholarship Generalitat, IFAE)
Gabriel Jover	Neutrinos (Scholarship MEC-FPI, UAB)
Olga Norniella (until 4/07)	CDF (Project Contract, IFAE)
Federico Nova	Neutrinos (Scholarship MEC-FPU, UAB)
Carlos Osuna	ATLAS (Scholarship MEC-FPI, IFAE)
Estel Pérez	ATLAS (Scholarship MEC-FPU, IFAE)



Xavier Portell (until 3/07)	CDF (Project Contract, IFAE)
Neus Puchades (since 7/07)	MAGIC (Scholarship MEC-FPI, IFAE)
Ana Rodríguez (until May 2007)	Neutrinos (Scholarship MEC-FPI, UAB)
Oriol Saltó	CDF (Scholarship Generalitat, IFAE )
Ester Segura	ATLAS (Scholarship MEC-FPU, IFAE)
Nuria Sidro	MAGIC (Project Contract, IFAE)
Francesc Vives	ATLAS (Project Contract, IFAE)
Matteo Volpi	ATLAS (Scholarship Generalitat, IFAE)
Diego Tescaro (since 7/07)	MAGIC (Scholarship MEC-FPU, IFAE)
Volker Vorkerk	ATLAS (Scholarship MEC-FPI, IFAE)
Roberta Zanin	MAGIC (Project Contract, IFAE)

### Administrative Personnel

Josep Gaya	IFAE/ UAB, Senior Administrator
Cristina Cárdenas	UAB/ IFAE, Secretary
Natalia Alonso	MAGIC/X-rays, Administrative Assistant
Ramon Santos	IFAE, Administrative Assistant

### Technicians

Alex González	Electronic Technician, IFAE
Javier Gaweda	Mechanical Technician, IFAE
Karl Kölle	MAGIC Telescope Manager

## THEORY DIVISION

### Faculty

Emili Bagan	Associate Professor, UAB
Marià Baig	Associate Professor, UAB
Rafel Escribano	Research Assoc. Prof. (Ramón y Cajal), UAB
Josep Antoni Grifols	Professor, UAB
Mathias Jamin	Research Professor, ICREA
Eduard Massó	Professor, UAB
Joaquim Matias	Research Assoc. Prof. (Ramón y Cajal), UAB
Antoni Méndez	Professor, UAB

Ramon Muñoz-Tapia	Associate Professor, UAB
Ramon Pascual	Professor, UAB
Santi Peris	Associate Professor, UAB
Antonio Pineda	Associate Professor, UAB
Alex Pomarol	Associate Professor, UAB
Mariano Quiros	Research Professor, ICREA

### Scientific Post-Docs

Aldo Cotrone	Post-doc IFAE (at UB)
Gabriel Fernández	Post-doc Juan de la Cierva
Thomas Konstandin (since 11/2007)	Post-doc Universenet
Alessio Provenza (since 11/2007)	Post-doc IFAE (at UAB)
Juan José Sanz (since 12/2007)	Post-doc Juan de la Cierva
Felix Schwab	Post-doc DFG and BMBF
Andrea Wulzer (until 10/2007)	Post-doc IFAE (at UAB)

### Visiting Scientists

Pedro Silva	Institut de Ciències de l'Espai
-------------	---------------------------------

### Doctoral Students

Mariona Aspachs	Scholarship MEC
Santi Béjar (until 9/2007)	Teaching Assistant
Joan Antoni Cabrer (since 09/2007)	Teaching Assistant
Martí Cuquet (since 09/2007)	Scholarship UAB (PIF)
David Diego	Teaching Assistant
Oriol Domènech (since 09/2007)	Teaching Assistant
Pere Masjuan	Teaching Assistant
Àlex Monras (until 9/2007)	Scholarship MEC
Germano Nardini	Scholarship MEC
Antonio Picon	Scholarship MEC
Javier Redondo (until 9/2007)	Scholarship MEC
Carles Rodó	Teaching Assistant
Diogo R. Boito (since 09/2007)	Scholarship MEC
Oriol Romero-Isart	Scholarship MEC

Marc Ramon (since 09/2007)	Scholarship UAB (PIF)
Javier Serra	Scholarship MEC
Javier Virto (until 9/2007)	Teaching Assistant
Gabriel Zsembinski (until 9/2007)	Scholarship UAB

### **Administrative Personnel**

Montse Cabrera	IFAE/ UAB
Montse Galán (since 10/2007)	IFAE/ UAB



## 6. INSTITUTIONAL ACTIVITIES

---

### 6.1 DIPLOMA THESES

#### Experimental Division

**Diego Tescaro**

Title: *Timing analysis of the MAGIC telescope data after the installation of the ultra-fast 2 Gsamples/s FADC readout.*

Supervisor: Abelardo Moralejo Olaizola

Date: 30/09/07

#### Theory Division

**Pere Masjuan**

Title: *A rational Approach to Resonance Saturation in Large  $N_c$  QCD.*

Supervisor: Santiago Peris

Date: 12/09/07

**Germano Nardini**

Title: *Effective theory of the light stop scenarii*

Supervisor: Mariano Quirós

Date: 13/11/07

### 6.2 DOCTORAL THESES

#### Experimental Division

**Xavier Portell Bueso**

Title: *Search for Gluino and Squark Production in Multi-Jets plus Missing ET Final Status at the Tevatron Using the CDF Detector.*

Supervisor: Mario Martínez Pérez

Date: 23/03/2007

**Olga Norniella Francisco**

Title: *Inclusive jet Production Studies at the Tevatron using the CDF Detector.*

Supervisor: Mario Martínez Perez

Date: 30/03/2007

**Ana Rodríguez Marrero**

Title: *Measurement of the Exclusive and Inclusive Single Pion Neutrino Interaction Cross Section in a Carbon Target Using the SciBar Detector at the K2K Experiment.*

Supervisor: Federico Sánchez Nieto

Date: 18/05/07

**Ester Aliu Fusté**

Title: *VHE gamma-ray observations of Northern sky pulsar wind nebulae with the MAGIC Telescope.*

Supervisor: Enrique Fernández

Date: 05/10/07

#### Theory Division

**Javier Redondo Martín**

Title: *Can the PVLAS particle be compatible with the astrophysical bounds?*

Supervisor: Eduard Massó Soler

Date: 01/06/07

**Alex Monràs Blasi**

Title: *Optimal estimation of quantum states and operations.*

Supervisor: Emili Bagan Capella

Date: 06/07/07

**Gabriel Zsembinski**

Title: *Light scalar fields in a dark universe : models of inflation, dark energy and dark matter.*

Supervisor: Eduard Massó Soler.

Date: 25/07/07

**Javier Virto Iñigo**

Title: *Topics in hadronic B decays.*

Supervisor: Joaquim Matias

Date: 17/12/07

### 6.3 PUBLICATIONS

#### Experimental Division

**Publications of the ALEPH Group**

*S. Bravo, M.P. Casado, M. Chmeissani, J.M. Crespo, E. Fernández, M. Fernández-Bosman, Ll. Garrido, M. Martínez, A. Pacheco, H. Ruiz with the ALEPH Collaboration*

Search for Higgs bosons decaying to WW in  $e^+e^-$  collisions at LEP

S. Schael *et al.* Eur.Phys.J.C49:439-455, 2007

Fermion pair production in  $e^+e^-$  collisions at 189–209 GeV and constraints on physics beyond the standard model

S. Schael *et al.* Eur. Phys. J. C 49, 411–437, 2007

Measurement of the Cross Section for open b-Quark Production in Two-Photon Interactions at LEP  
S. Schael *et al.* Journal of HEP. 0709, 102, 2007

### Publications of the ATLAS Group

M. Bosman, C. Padilla, I. Riu, S. Sushkov  
with W. Vandelli and 31 authors from ATLAS Collaboration

Strategies and tools for ATLAS online monitoring  
IEEE Trans.Nucl.Sci.54:609-615, 2007

M. Bosman, M.P. Casado, H. Garitaonandia, C. Osuna,  
C. Padilla, E. Segura, S. Sushkov  
with K. Kordas and 192 authors from ATLAS Collaboration

The ATLAS Data Acquisition and Trigger: Concept, design and status  
Nucl.Phys.Proc.Suppl.172:178-182, 2007

M. Bosman, C. Padilla, I. Riu, S. Sushkov  
with D. Salvatore and 31 authors from ATLAS Collaboration

The GNAM system in the ATLAS online monitoring framework  
Nucl.Phys.Proc.Suppl.172:317-320, 2007

U. Blumenschein  
and TileCal authors from ATLAS Collaboration  
Installation, commissioning and operation of the tile hadron calorimeter of ATLAS  
Nucl.Instrum.Meth.A572:24-25, 2007

U. Blumenschein  
with K. Anderson and 10 authors from TileCal ATLAS Collaboration  
A mobile data acquisition system  
JINST 2:P07002, 2007

H. Garitaonandia  
with A. Forti, J. Masik, T. Wengler, S.C. Wheeler  
Using the Grid to Test the ATLAS Trigger and Data Acquisition System at Large Scale  
IEEE Trans.Nucl.Sci.54:1767-1772, 2007

### Publications of the CDF Group

M. Cavalli-Sforza; G. De Lorenzo, M. D'Onofrio, R. Lefevre, M. Martínez, O. Norniella, X. Portell, O. Saltó:

First Flavor-Tagged Determination of Bounds on Mixing-Induced CP Violation in  $B_0(s) \rightarrow J/\psi \phi$  Decays  
T. Aaltonen *et al.*  
hep-ex /0712.2397 Submitted to Phys.Rev.Lett.

Observation of Exclusive Dijet Production at the Fermilab Tevatron p-pbar Collider  
T. Aaltonen *et al.*  
hep-ex /0712.0604 [Submitted to Phys.Rev.Lett.]

Search for chargino-neutralino production in p anti-p collisions at 1.96-TeV with high-p(T) leptons.  
T. Aaltonen *et al.*  
hep-ex /0711.3161 [Submitted to Phys.Rev.D.]

Measurement of correlated b-bbar production in p-pbar collisions at  $s^{1/2} = 1960$  GeV.  
T. Aaltonen *et al.*  
hep-ex/0710.1895

Search for resonant t anti-t production in p anti-p collisions at  $s^{1/2} = 1.96$ -TeV.  
T. Aaltonen *et al.*  
hep-ex /0709.0705 Submitted to Phys.Rev.Lett.

First Run II Measurement of the W Boson Mass.  
T. Aaltonen *et al.*  
hep-ex/0708.3642 Submitted to Phys. Rev. D

Search for Direct Pair Production of Supersymmetric Top and Supersymmetric Bottom Quarks in p anti-p Collisions at  $s^{1/2} = 1.96$ -TeV.  
T. Aaltonen *et al.*  
Phys.Rev.D76:072010, 2007

Search for new physics in high mass electron-positron events in p anti-p collisions at  $s^{1/2} = 1.96$ -TeV.  
T. Aaltonen *et al.*  
Phys.Rev.Lett.99:171802, 2007

Search for exclusive gamma gamma production in hadron-hadron collisions.  
T. Aaltonen *et al.*  
Phys.Rev.Lett.99:242002, 2007

Search for chargino-neutralino production in p anti-p collisions at  $s^{1/2} = 1.96$ -TeV.  
T. Aaltonen *et al.*  
Phys.Rev.Lett.99:191806, 2007

Search for a high-mass diphoton state and limits on Randall-Sundrum gravitons at CDF.  
T. Aaltonen *et al.*  
Phys.Rev.Lett.99:171801, 2007

Observation and mass measurement of the baryon  $\Xi(b)$ .  
T. Aaltonen *et al.*  
Phys.Rev.Lett.99:052002, 2007

First measurement of the W boson mass in run II of the Tevatron  
By CDF Collaboration (T. Aaltonen *et al.*)  
Phys.Rev.Lett.99:151801, 2007

First observation of heavy baryons  $\Sigma(b)$  and  $\Sigma(b)^*$ .  
T. Aaltonen *et al.*  
Phys.Rev.Lett.99:202001, 2007

Measurement of the  $p$  anti- $p \rightarrow t$  anti- $t$  production cross-section and the top quark mass at  $s^{**}(1/2) = 1.96$ -TeV in the all-hadronic decay mode.  
T. Aaltonen *et al.*  
Phys.Rev.D76:072009, 2007

Search for New Particles Leading to Z+jets Final States in  $p$  anti- $p$  Collisions at  $s^{**}(1/2) = 1.96$ -TeV.  
T. Aaltonen *et al.*  
Phys.Rev.D76:072006, 2007

Limits on Anomalous Triple Gauge Couplings in  $p$  anti- $p$  Collisions at  $s^{**}(1/2) = 1.96$ -TeV.  
T. Aaltonen *et al.*  
Phys.Rev.D76:111103, 2007

Measurement of the top-quark mass using missing  $E(T) +$  jets events with secondary vertex b-tagging at CDF II.  
T. Aaltonen *et al.*  
Phys.Rev.D75:111103, 2007

Search for heavy, long-lived particles that decay to photons at CDF II.  
A. Abulencia *et al.*  
Phys.Rev.Lett.99:121801, 2007

Polarization of  $J/\psi$  and  $\psi(2S)$  mesons produced in  $p$  anti- $p$  collisions at  $s^{**}(1/2) = 1.96$ -TeV.  
A. Abulencia *et al.*  
Phys.Rev.Lett.99:132001, 2007

Precise measurement of the top quark mass in the lepton+jets topology at CDF II.  
A. Abulencia *et al.*  
Phys.Rev.Lett.99:182002, 2007

Measurement of  $\sigma(\chi(c2)B(\chi(c2)) \rightarrow J/\psi \text{ gamma}) / \sigma(\chi(c1)B(\chi(c1)) \rightarrow J/\psi \text{ gamma})$  in  $p$  anti- $p$  collisions at  $s^{**}(1/2) = 1.96$ -TeV.  
A. Abulencia *et al.*  
Phys.Rev.Lett.98:232001, 2007

Inclusive search for new physics with like-sign dilepton events in  $p$  anti- $p$  collisions at  $s^{**}(1/2) = 1.96$ -TeV.  
A. Abulencia *et al.*  
Phys.Rev.Lett.98:221803, 2007

First Measurement of the Ratio of Central-Electron to Forward-Electron W Partial Cross Sections in  $p$  anti- $p$  Collisions at  $s^{**}(1/2) = 1.96$  TeV.  
A. Abulencia *et al.*  
Phys.Rev.Lett.98:251801, 2007

Search for new physics in lepton + photon + X events with 929  $\text{pb}^{**}(-1)$  of  $p$  anti- $p$  collisions at  $s^{**}(1/2) = 1.96$ -TeV. A. Abulencia *et al.*  
Phys.Rev.D75:112001, 2007

Observation of WZ Production.  
A. Abulencia *et al.*  
Phys.Rev.Lett.98:161801, 2007

Measurement of the Inclusive Jet Cross Section using the  $k(T)$  algorithm in  $p$  anti- $p$  collisions at  $s^{**}(1/2) = 1.96$ -TeV with the CDF II Detector.  
A. Abulencia *et al.* Phys.Rev.D75:092006, 2007.  
(Erratum *ibid.*D75:119901, 2007)

Search for anomalous production of multi-lepton events in  $p$  anti- $p$  collisions at  $s^{**}(1/2) = 1.96$ -TeV.  
A. Abulencia *et al.*  
Phys.Rev.Lett.98:131804, 2007

### Publications of the MAGIC Group

*E. Aliu, A. Armada, O. Blanch, J. Cortina, E. Domingo, M. Errando, E. Fernández, R. Firpo, J. Flix, M. Gaug, J. Lopez, M. Martínez, E. Oña-Wilhelmi, J. Rico, N. Sidro, with the MAGIC Collaboration:*

Detection of VHE radiation from the BL Lac PG 1553+113 with the MAGIC telescope  
J. Albert *et al.*  
Astrophys. J. Lett., 654 (2007) L119-L122.

Observation of VHE gamma-rays from Cassiopeia A with the MAGIC telescope  
J. Albert *et al.*  
Astron. Astrophys. Lett. 474 (2007) 937-940.

First bounds on the very high energy gamma-ray emission from Arp 220  
J. Albert *et al.*  
Astrophys. J., 658 (2007) 245.

Observation of very high energy gamma-rays from the AGN 1ES 2344+514 in a low emission state with the MAGIC telescope.  
J. Albert *et al.*  
Astrophys. J. 662:892, 2007

Observations of MKN 421 with the MAGIC Telescope  
J. Albert *et al.*  
Astrophys. J. 663:125-138, 2007

Discovery of VHE Radiation from IC443 with the MAGIC Telescope  
J. Albert *et al.*  
Astrophys. J. 664:L87-L90, 2007

Very High Energy Gamma-ray Radiation from the Stellar-mass Black Hole Cygnus X-1.

J. Albert *et al.*

Astrophys. J. 665:L51, 2007

MAGIC Upper Limits on the Very High Energy Emission from Gamma-Ray Bursts

J. Albert *et al.*

Astrophys. J. 667 (2007) 358.

Discovery of Very High Energy gamma-rays from 1ES 1011+496 at  $z=0.212$

J. Albert *et al.*,

Astrophys. J. 667 (2007) L21.

Variable VHE gamma-ray emission from Markarian 501.

J. Albert *et al.*

Astrophys. J. 669:862, 2007

Constraints on the steady and pulsed VHE gamma-ray emission from observation of PSR B1951+32/CTB 80 with the MAGIC Telescope

J. Albert *et al.*

Astrophys. J. 669:1143-1149, 2007

Unfolding of differential energy spectra in the MAGIC experiment

J. Albert *et al.*

Nucl.Instrum.Meth. A583:494-506, 2007

### **Publications of the Neutrino Group**

J. Alcaraz, E. Fernández, G. Jover, T. Lux, F. Nova, A. Rodríguez, F. Sánchez

Bulk micromegas detectors for large TPC applications

J. Bouchez *et al.*

Nucl.Instrum.Meth. A 574 (2007) 425.

Characterization of a High Resolution Triple Gas Electron Multiplier (Gem) Detector

N. Abgrall *et al.*

Nucl.Phys.Proc.Suppl. 172 (2007) 234.

F. Sánchez

Neutrino interactions: Experiments

Nucl.Phys.Proc.Suppl. 168 (2007) 183.

### **Other Publications**

F. Sánchez with the HERA-B Collaboration:

Measurement of  $D^0$ ,  $D^+$ ,  $D_s^+$  and  $D^{*+}$  Production in Fixed Target 920 GeV Proton-Nucleus Collisions

Abt *et al.*

Eur.Phys. J. C 52 (2007) 531

Luminosity determination at HERA-B

Abt *et al.*

Nucl.Instrum.Meth. A 582 (2007) 401

Bottom production cross section from double muonic decays of b-hadrons in 920-GeV proton nucleus collision,

Abt *et al.*,

Phys.Lett. B 650 (2007) 103

A measurement of the  $\psi'$  to  $J/\psi$  production ratio in 920-GeV proton nucleus interactions

Abt *et al.*,

Eur.Phys.J. C 49(2007) 545

$K^*0$  and  $\Phi$  meson production in proton nucleus interactions at  $s^{*(1/2)} = 41.6$ -GeV

Abt *et al.*,

Eur. Phys. J. C 50 (2007) 315

R. Miquel

Cosmology with type-Ia supernovae

J. Phys. A 40 (2007) 6743 and astro-ph/0703459

A. G. Kim and R. Miquel

Measuring Type Ia Supernova Distances and Redshifts From Their Multi-band Light Curves

Astropart. Phys. 28 (2007) 448 and [arXiv: astro-ph/0708.2745

E. V. Linder and R. Miquel

Tainted Evidence: Cosmological Model Selection vs. Fitting

astro-ph/0702542.

### **Theory Division**

E. Bagan, J. Calsamiglia, R. Muñoz-Tapia *et al.*

How to hide a secret direction

New J. Phys. 9 (2007) 244

The Quantum Chernoff Bound

Phys. Rev. Lett. 98, 160501 (2007)

E. Bagan *et al.*

Quantum-limited metrology with product states

Phys. Rev. A 77, 012317 (2007)

R. Escrivano

Is  $\eta'$  partially made of gluonium?

hep-ph/0712.1814

R. Escrivano *et al.*

On the gluon content of the  $\eta$  and  $\eta'$  mesons

JHEP 0705:006, 2007



*R. Escribano*  
The  $\phi \rightarrow K^0 K^0 \gamma$  decay,  
Eur.Phys.J.A31:454-457, 2007

*P. Masjuan, S. Peris*  
A Rational Approach to Resonance Saturation in large-Nc  
QCD  
JHEP05 (2007) 040; hep-ph/0704.1247

*E. Massó, J. Redondo et al.*

Light scalars coupled to photons and non-newtonian  
forces  
Phys.Rev. Lett.98:131802, 2007; hep-ph/0610286

The Need for purely laboratory-based axion-like particle  
searches  
DCPT-06-136, DESY-06-188, IPPP-06-68, UAB-FT-612,  
Oct 2006  
Phys.Rev.D75:013004, 2007; hep-ph/0610203

*E. Massó et al.*  
Probing long-range leptonic forces with solar and reactor  
neutrinos  
JCAP 0701:005, 2007; hep-ph/0609094

*J. Matias, J. Virto et al.*  
Penguin-mediated  $B(d,s) \rightarrow VV$  decays and the  $B(s) -$   
anti- $B(s)$  mixing angle  
Phys. Rev. D76:074005, 2007

*J. Matias*  
Merging flavour symmetries with QCD  
factorisation for  $B \rightarrow KK$  decays  
Acta Phys. Polon. B38:2901-2910, 2007

*J. Matias et al.*  
Huge right-handed current effects in  $B \rightarrow K^*(\rightarrow K\pi)l^+\Gamma^-$   
supersymmetry  
JHEP 0704:058, 2007

Extracting alpha from  $B_0(d) \rightarrow K_0$  anti- $K_0$  decays  
Phys. Rev. D75:093004, 2007

SuperB: A High-Luminosity Asymmetric  $e^+ e^-$  Super  
Flavor Factory. Conceptual Design Report  
hep-ex/0709.0451

*G. Nardini, M. Quiros, A. Wulzer*  
A Confining Strong First-Order Electroweak Phase  
Transition  
Journal of High Energy Physics 0709 (2007) 077

*A. Pineda et al.*  
Constraints on Regge Models from Perturbation Theory  
JHEP0710, 061 (2007)

*A. Pomarol et al.*  
Light custodians in natural composite Higgs models  
Phys. Rev. D75 (2007) 055014

The Strongly-Interacting Light Higgs  
JHEP 0706, 045 (2007)

The holographic composite Higgs  
Comptes Rendus Physique (bf) (2007) 1058

*M. Quiros*  
Field Theory at Finite Temperature and Phase Transitions  
Acta Physica Polonica B38 (2007) 3661-3703

*M. Quiros et al.*  
Unparticles-Higgs Interplay  
Journal of High Energy Physics 0710 (2007) 094

*M. Quiros*  
Electroweak Baryogenesis  
J. Phys. A: Math. Theor. 40 (2007) 6573-6581

*M. Quiros et al.*  
Novel Effects in Electroweak Breaking from a Hidden  
Sector  
Physical Review D76 (2007) 076004

## 6.4 TALKS BY IFAE MEMBERS

### Experimental Division

**A. Attal**  
“Z+jets Production at the Tevatron (CDF)”  
European Physics Society (EPS 07)  
Manchester (UK), July 2007

**U. Blumenschein**  
“Status of the Tile Calorimeter”  
ATLAS Overview week  
CERN (Switzerland), February 2007

**M. Cavalli-Sforza**  
“TileCal energy scale, from test beam to ATLAS physics”  
Summary talk, TileCal calibration workshop  
CERN (Switzerland), November 2007  
“The particle physics revolution, 1973-1977”  
IFAE seminar  
Barcelona (Spain), June 2007

**J. Cortina**  
“CTA: Cherenkov Telescope Array”  
RENATA07  
Valencia (Spain), September 2007

**E. Fernández**  
“The ApPEC Roadmap”

IVth Ilias General Meeting  
Chambery (France), February 2007.

**R. Firpo**

*“Extragalactic observations with MAGIC”*  
The 2007 Europhysics Conference on High Energy  
Physics  
Manchester (UK), July 2007

**G. De Lorenzo**

*“Inclusive Search for Squark/Gluino Production at CDF”*  
Pheno 2007  
Madison (USA), May 2007  
*“Search for Squark/Gluino Production at CDF”*  
APS Meeting  
Florida (USA), April 2007.

**M. Martínez**

*“Very high energy gamma ray astrophysics”*  
ASPERA SC meeting  
Paris (France), March 2007  
*“Instrumentation for VHE gamma ray astrophysics”*  
ASTRID Workshop  
Madrid (Spain), May 2007  
*“Very high energy gamma ray astrophysics”*  
ASPERA General Meeting  
Amsterdam (Netherlands), September 2007  
*“CTA”*  
Toward the Future of Very High Energy Gamma-ray  
Astronomy Conference  
SLAC (USA), November 2007

**M. Martínez-Pérez**

*“SUSY and non-MSSM Higgs Searches”*  
Lepton Photon Conference,  
Daegu (Korea), August 2007  
*“High-Pt Physics at the Tevatron”*  
Fermi Institute  
University of Chicago (USA), June 2007

**D. Mazin**

*“Successful ToO Triggers on the extragalactic sources  
with the MAGIC Telescope”*  
XXX ICRC  
Mérida (México), July 2007  
*“Possible optical-TeV correlation in blazars and new  
constraints on extragalactic background light derived  
from MAGIC data of distant sources”*  
INTEGRAL V Anniversary Workshop  
Cagliari (Italy), October 2007  
*“Observations of AGNs with the MAGIC Telescope”*  
First GLAST Symposium  
Stanford University (EEUU), February 2007

**R. Miquel**

*“The SuperNova Acceleration Probe (SNAP)”*

XIX Rencontres de Blois, Matter and energy in the  
Universe: from nucleosynthesis to cosmology  
Blois (France), May 2007

**M. D’Onofrio**

*“Inclusive Search for Squark/Gluino Production at CDF”*  
SUSY07  
Karlsruhe (Germany), July 2007  
*“Measurements of  $W+jet(s)$  and  $Z+jet(s)$  production  
cross sections at CDF”*  
Deep Inelastic Scattering (DIS 07)  
Munich (Germany), April 2007

**X. Portell**

*“CDF squarks and gluinos”*  
Euro-GDR Supersymmetry International Meeting,  
Brussels (Belgium), November 2007  
*“Search for Squarks and Gluinos at the Tevatron”*  
European Physics Society (EPS 07)  
Manchester (UK), July 2007

**J. Rico**

*“Observations of microquasar candidates with the  
MAGIC telescope in the TeV domain”*  
INTEGRAL V Anniversary Workshop  
Cagliari (Italy), October 2007  
*“Observations of microquasar candidates with the  
MAGIC telescope in the TeV domain”*  
I Workshop on High Energy Phenomena in  
Relativistic Outflows  
Dublin (Ireland), September 2007  
*“Observations of microquasars with the MAGIC  
telescope”*  
XXX ICRC  
Mérida (México), July 2007  
*“MAGIC and MAGIC-II”*  
RENATA07  
Valencia (Spain), September 2007  
*“First Results of Galactic Observation with MAGIC”*  
XII International Workshop on Neutrino Telescopes  
Venice (Italy), February 2007

**I. Riu**

*“Integration of the Trigger and Data Acquisition Systems  
in ATLAS”*  
IEEE Real Time Conference 2007 (RT 07)  
Batavia, Illinois (USA), April-May 2007  
*“The Trigger System of ATLAS”*  
Four Seas Conference  
Iasi (Romania), June 2007

**O. Saltó**

*“Measurement of the Inclusive  $Z+jet(s)$  Production Cross  
Section at CDF”*  
Joint Experimental-Theoretical Seminar  
Fermilab (USA), August 2007

*“Boson + Jets at CDF”*

Pheno 2007

Madison (USA), May 2007

*“Measurement of the Inclusive Z+jet(s) Production Cross Section at CDF”*

APS Meeting

Florida (USA), April 2007

*“QCD studies at the Tevatron”*

Rencontres de Physique de La Vallée d'Aoste

La Thuile (Aosta), March 2007

### **N. Sidro**

*“Two years of observations of LSI +61 303”*

XXX ICRC

Merida (Mexico), July 2007

## **Theory Division**

**M. Aspachs, J. Calsamiglia, A. Monràs, R. Muñoz-Tapia, E. Bagan**

*“Phase estimation with Gaussian states”*

QIPC International Conference

Barcelona (Spain), October 2007

### **E. Bagan**

*“The Quantum Chernoff Bound and its Induced Metric”*

Special seminar series on quantum information at NII

National Institute of Informatics (NII)

Tokyo (Japan), March 2007

*“Quantum State Discrimination and the Quantum Chernoff Bound”*

4th Central European Quantum Information Processing Workshop

Valtice (Czech Republic), June 2007

*“State Discrimination, the Quantum Chernoff Bound and its Induced Metric”*

Noise Information & Complexity at Quantum Scale

Ettore Majorana Center

Erice (Italy), November 2007

### **R. Escribano**

*“On the gluon content of the  $\eta$  and  $\eta'$  mesons”*

12th International Conference on Hadron Spectroscopy (Hadron 07)

Frascati (Italy), October 2007

*“Scalar meson exchange in  $V \rightarrow P^0 P^0 \gamma$  decays”*

Università di Roma,

Roma (Italy), July 2007

*“Scalar meson exchange in  $V \rightarrow P^0 P^0 \gamma$  decays”*

ETA07 Workshop

Peñíscola (Spain), May 2007

*“On the gluon content of the  $\eta$  and  $\eta'$  mesons”*

Laboratori Nazionali di Frascati

Frascati (Italy), March 2007

### **E. Massó**

*“Theoretical Status of Astroparticle Physics”*

21st Int. Workshop on Weak Interactions and Neutrinos (WIN07)

Saha Institute, Calcuta (India), January.2007

### **J. Matias**

*“ $B^0 \rightarrow K^{*0} (\rightarrow K\pi) l^+ l^-$  in supersymmetry: AT1, AT2 and more”*

LHCb-meeting, Theory Division

CERN (Switzerland), April 2007

*“Probing right-handed currents with the AT2 asymmetry”*

Second Workshop on Flavour Dynamics

Albufeira (Portugal), November 2007

*“The transverse asymmetry AT2 in the SM and supersymmetry”*

Flavianet Meeting EuroFlavour07

Orsay (France), November. 2007

### **R. Muñoz-Tapia**

*“Optimal discrimination of mixed states and their metric”*

QIP Workshop 2007

Brisbane (Australia), January-February. 2007

*“How to hide a secret direction  $n'$ ”*

XXXI Reunion Bienal de la Real Sociedad de Física

Granada (Spain), September 2007

*“Recycling of Information”*

Applied Quantum Measurement (AQM)

Leiden (Netherlands), November 2007

### **S. Peris**

*“What is resonance saturation?”*

Int. Conference Euroflavor07

Paris (France), November. 2007

### **A. Pineda**

*“Non-Relativistic Quantum Mechanics Versus Quantum Field Theories”*

Congrés 42nd Rencontres de Moriond on QCD and Hadronic Interactions

Moriond, La Thuile (Italia), 2007

*“Nuclear Effects In Atomic Physics From Effective Theories”*

Workshop on fundamental Neutron Physics

Seattle (USA), 2007

*“Inclusive electromagnetic decays of heavy quarkonium”*

International Workshop on Heavy Quarkonium 2007

DESY (Germany), 2007

*“Preasymptotic effects in  $1/n$  and  $1/N_c$  in current-current correlators”*

Plenary talk

FLAVIANET Meeting EUROFLAVOUR 07

Paris (France), 2007

*“Effective Field Theories for Non-Relativistic Systems”*

Universidad de Paris, (France), February 2007

*“Effective Field Theories for Non-Relativistic Systems”*

Heidelberg (MPI), (Germany), March 2007

### **A. Pomarol**

*"The strongly-interacting light Higgs"*

42th Rencontres de Moriond: Electroweak Interactions and Unified Theories,

La Thuile (Italy), March 2007

*"New physics at new colliders"*

XXXV International Meeting On Fundamental Physics Santiago de Compostela (Spain), May 2007

*"Extra dimensional Theories"*

31st Johns Hopkins Workshop: Physics at the LHC - A Challenge for Theory and Experiment

Heidelberg (Germany), August 2007

*"Recent Topics on ElectroWeak Symmetry Breaking"*

EURO-GDR SUSY 2007 International Meeting Brussels (Belgium), November 2007

*"The composite Higgs alternative"*

Universidad de Granada (Spain), November 2007

*"The composite Higgs alternative"*

Universitat de Barcelona (Spain), November 2007.

### **M. Quiros**

*"The Higgs Connection of Unparticles"*

Conference: "Detecting the Unexpected"

University of California at Davis (USA), November 2007

*"Baryogenesis from a Supercooled Phase Transition"*

Conference: "Baryogenesis Confronts Experiment"

Kavli Institute for Cosmological Physics at the University of Chicago

Chicago, Illinois (USA), November 2007

*"A supercooled electroweak phase transition"*

Conference: Eotvos-Cornell 2007 Summer Workshop on Particle Theory: Beyond the Standard Model at the Dawn of the LHC Era"

Budapest (Hungary), June 2007

*"A supercooled electroweak phase transition"*

Conference: "Tenth European Meeting: From the Planck Scale to electroweak Scale"

Warsaw (Poland), June 2007

## **6.5 PARTICIPATION IN EXTERNAL COMMITTEES**

### **Georges Blanchot**

- Currently at CERN. Chief engineer in charge of cabling, grounding and electromagnetic interference matters for ATLAS (since 2004).

### **Martine Bosman**

- ATLAS Speakers Committee. Elected by ATLAS Collaboration Board. From July 2005 to June 2008. Member July 2005 to June 2007 – Chair July 2007-June 2008.

### **Matteo Cavalli-Sforza**

- CERN Scientific Policy Committee. Member. Appointed by Director General of CERN. September 2002 – December 2008.
- Member of Conseil scientifique du LPNHE - Laboratoire de Physique Nucléaire et de Hautes Energies, CNRS et Universités de Paris 6 et Paris 7, Appointed by Director of LPNHE, 2005 - 2008
- Chairman of Scientific Committee of the Laboratori Nazionali di Frascati of INFN. Appointed by President of INFN, 2006-2009

### **Juan Cortina**

- MAGIC: Convenor of Galactic Sources Working Group. Since 2005
- Deputy Physics Coordinator. Since 2007
- Member of Executive Committee of RENATA (red Nacional de Astropartículas). Since 2006

### **Manuel Delfino**

- Member of the "Grupo de interés español sobre Grid y e-Ciencia (IRISGrid)." Since 2002.
- Member of the International High Energy Physics Computing Coordination Committee (IHEP-CCC). Since 2004.
- Member Subcommittee ICFA International High Energy Physics Computing Coordination Committee. Since 2004.
- Coordinator for Spain and Portugal of the Executive Committee of the project Enablin Grids for E-Science in Europe (UE) Framework VI Project). Since 2003.
- Elected Member of the Project Overview Board - LHC Computing Grid Project (CERN). Since 2003.
- Representative of Spain to the LHC Computing Grid Implementation Committee (CERN). Since 2002.

### **Enrique Fernández**

- CERN Scientific Policy Committee. Member. Appointed by Director General of CERN. Since January 2005.

- Particle and Nuclear Astrophysics and Gravitational International Committee (PANAGIC).  
Chair, since August 2005, nominated by IUPAP. Member since October 2000.
- Peer Review Committee of ApPEC (Astroparticle Physics European Coordinating Committee).  
Member: nominated by ApPEC Steering Committee. Since January 2001.
- Member of CVI (Comitato de Valutazione Interna) of the INFN.  
Appointed by Director of INFN (Italy). Since 2006-.
- Member International Advisory Board of the Henderson-DUSEL National Underground Laboratory.  
Appointed by Head of Henderson-DUSEL Initiative. State University of New York at Stony Brook.

#### **Ilya Korolkov**

- Luminosity Task Force of ATLAS TileCal Representative. Appointed by TileCal Project Leader. From April 2005.
- Tile Calorimeter Institute Board Member. Nominated by IFAE/ATLAS Project Leader. From August 2004.

#### **Manel Martínez**

- MAGIC Steering Committee. Spokesperson for MAGIC Collaboration: nominated by MAGIC Steering Committee.
- Finance Subcommittee of “Instituto de Astrofísica de Canarias”.  
Member: nominated by MAGIC Steering Committee. Since January 2001.

#### **Mario Martínez**

- Member of LHCC Committee at CERN since January 2005.

#### **Ramon Miquel**

- One of two members for Spain of DES Management Committee. Since 2007

#### **Abelardo Moralejo**

- MAGIC Executive Board:

Software Coordinator of the MAGIC Collaboration, since November 2006

#### **Andreu Pacheco**

- Member of the Collaboration Board of the project Enabling Grids for E-Science in Europe (UE Framework VI Project). Since 2004.
- Member of the LCG Grid Deployment Board (CERN). Since 2004.
- Member of the Atlas International Computing Board (CERN). Since 2003.

## **6.6 SEMINARS ORGANIZED BY IFAE**

Date: 11/01/07

Title: Rare  $K_L \rightarrow \pi^0 \eta \eta$  decay

Speaker: Sasha Ostankov (Protvino)

Date: 12/01/07

Title: Search for Anomalous Production of Multi-lepton Events at CDF

Speaker: Alon Attal (UCLA/IFAE)

Date: 19/01/07

Title: Gluon-Induced Z-Boson Pair Production at the LHC

Speaker: Philipp Mertsch (Univ. Würzburg)

Date: 22/01/07

Title: Evidence for Production of Single Top Quarks at D0 and a First Direct Measurement of  $|V_{tb}|$

Speaker: Aran Garcia-Bellido (University of Washington)

Date: 9/02/07

Title: QCD matter in extreme conditions: an overview

Speaker: David d'Enterria (CERN, PH/EP)

Date: 16/02/07

Title: Extensions of quantum field theory based on new energy scales

Speaker: José Manuel Carmona (Universidad de Zaragoza)

Date: 20/02/07 (PIC)

Title: Propuestas para una gestión de datos Grid escalable

Speaker: Victor Méndez Muñoz (Dpto. de Computación y Sistemas, Ingeniería, Univ. Zaragoza)

Date: 23/02/07

Title: Charm Physics with Highly Improved Staggered Quarks

Speaker: Eduardo Follana (University of Glasgow)

Date: 27/02/07  
Title: A neural model of cross-modal association  
Speaker: Dr. Christian Neissner (Unidad de Fluidos del Inst. Pluridisciplinar, Univ. Complutense de Madrid)

Date: 27/02/07  
Title: Aspects of QCD from holography  
Speaker: Angel Paredes (École Polytechnique, Paris)

Date: 1/03/07  
Title: Melting of a Mott insulator with entangled pairs  
Speaker: Juan José Garcia-Ripoll (Univ. Complutense)

Date: 2/03/07  
Title: Beyond General Relativity  
Speaker: Bartomeu Fiol, (Universitat de Barcelona)

Date: 9/03/07  
Title: WIMP Dark Matter and the QCD Equation of State  
Speaker: Owe Philipsen (University of Muenster)

Date: 12/03/07  
Title: Leptogenesis  
Speaker: Yossi Nir (Weizmann Institute, Israel)

Date: 13/03/07  
Title: Relativistic corrections to the static inter-quark potential from lattice QCD  
Speaker: Miho Koma (University of Mainz)

Date: 16/03/07  
Title: Asymptotics, Mellin transform and Mellin-Barnes representation: applications in quantum field theory  
Speaker: Samuel Friot (Universitat de Barcelona)

Date: 16/03/07  
Title: W Top and Higgs at the Tevatron  
Speaker: Eva Halkiadakis

Date: 26/03/07  
Title: Double Beta Decay Outlook  
Speaker: Peter Vogel (Cal Tech)

Date: 27/03/07  
Title: A strongly coupled quark-gluon plasma in RHIC?  
Speaker: Cristina Manuel (IEEC-CSIC)

Date: 30/03/07  
Title: Neural parton distributions for the Large Hadron Collider  
Speaker: Juan Rojo (LPTHE, Université Paris VI-VII)

Date: 18/04/07  
Title: Low Energy  $e^+e^-$  Annihilation and Status of Muon ( $g-2$ )  
Speaker: Simon Eidelman (Novosibirsk, IYF)

Date: 24/04/07  
Title: Plasma instabilities in Quantum Chromodynamics?  
Speaker: Guy Moore (McGill University)

Date: 02/05/07  
Title: Theta(13) with reactor neutrinos  
Speaker: Anatael Cabrera (Laboratoire Astroparticule et Cosmologie)

Date: 9/05/07  
Title: How to identify hadronic molecules  
Speaker: Christoph Hanhart (Julich, Forschungszentrum)

Date: 11/05/07  
Title: Semiconductor nanostructures as components for quantum optics  
Speaker: Carlos Tejedor (Univ. Autónoma de Madrid)

Date: 17/05/07  
Title: First Neutrino oscillation results from MiniBoone  
Speaker: Michel Sorel (IFIC, Univ. de Valencia)

Date: 18/05/07  
Title: A new look at heavy ion collisions: preparing to the LHC  
Speaker: Carlos A. Salgado (U. di Roma)

Date: 18/05/07  
Title: Status of ICECUBE-Links with MAGIC  
Speaker: Elisa Bernardini (Astroparticle group at DESY)

Date: 21/05/07  
Title: LHC Physics  
Speaker: Manel Masip (Universidad de Granada)

Date: 30/05/07  
Title: BPS preons in supergravity and M-theory  
Speaker: José Adolfo de Azcárraga (Univ. de València and IFIC)

Date: 8/06/07  
Title: Localization of ultracold bosons in optical lattices  
Speaker: Tommaso Roscilde (Max-Planck Institute for Quantum Optics, Garching)

Date: 8/06/07  
Title: Quantumness of correlations and local broadcasting  
Speaker: Marco Piani (University of Innsbruck)

Date: 26/06/07  
Title: Constructing chiral invariant resonance lagrangians: renormalizable sectors  
Speaker: Juan Jose Sanz Cillero (Peking University)

Date: 27/06/07  
Title: The top quark from LHC to ILC  
Speaker: J. A. Aguilar-Saavedra (Univ. of Granada)

Date: 29/06/07  
 Title: De-Gravitation  
 Speaker: Gia Dvali (New York University)

Date: 3/07/07  
 Title: Bell inequality tests with photons  
 Speaker: Emilio Santos (Universidad de Cantabria)

Date: 3/07/07  
 Title: Quantum Mechanics with neutral kaons  
 Speaker: Gianni Garbarino (Universita' di Torino)

Date: 5/07/07  
 Title: Complementarity and entanglement in multipartite systems  
 Speaker: Janos A. Bergou (CUNY)

Date: 6/07/07  
 Title: Tabletop experiments vs large accelerators in hunting for new physics  
 Speaker: Alexander Penin (University of Karlsruhe)

Date: 13/07/07  
 Title: Physics Beyond the Standard Model and Multi-GeV neutrinos from Gamma-Ray  
 Speaker: Sarira Sahu (Instituto de Ciencias Nucleares, UNAM, Mexico)

Date: 7/09/07  
 Title: Lattice QCD results with twisted mass quarks  
 Speaker Istvan Montvay (DESY Hamburg)

Date: 12/09/07  
 Title: TimePix operation in a small TCP-like prototype at DESY  
 Speaker: Andreas Bamberger (Physikalisches Institut der Albert-Ludwigs-Universitat Freiburg)

Date: 13/09/07  
 Title: Probing the first stars with high energy gamma-ray absorption  
 Speaker: Tanja Kneiske (Univ. of Dortmund)

Date: 27/09/07  
 Title: Broadcasting in spin networks  
 Speaker: M. Cuquet (UAB)

Date: 28/09/07  
 Title: How to detect SUSY before the LHC  
 Speaker: Sven Heinemeyer (IFCA Santander)

Date: 26/10/07  
 Title: Gamma-ray binaries and microquasars some recent theoretical progress  
 Speaker: Gustavo Romero (Univ. Nacional de La Plata)

Date: 30/10/07  
 Title: Selection of the H to bb inclusive channel at CDF II

Speaker: Stefano Camarda (Univ. di Padova)

Date: 13/11/07  
 Title: State discrimination of Entangled States by Local Operations  
 Speaker: M. Hayashi (ERATO, Japan Science and Technology Agency)

Date: 16/11/07  
 Title: New Top Production Measurements at CDF  
 Speaker: Sebastian Grinstein (Harvard)

Date: 23/11/07  
 Title: Physics and astrophysics of strange matter  
 Speaker: Jes Madsen (Aarhus University, Denmark)

Date: 27/11/07  
 Title: Recent measurements on ultra-high energy cosmic rays  
 Speaker: Alan Watson (Univ. of Leeds)

Date: 27/11/07  
 Title: LHC: Status and preparations for operations  
 Speaker: Steve Myers (CERN)

Date: 28/11/07  
 Title: Large-Scale Inhomogeneities and Cosmological Acceleration  
 Speaker: Nikos Tetradis (University of Athens)

Date: 30/11/07  
 Title: SUSY Search at Future Collider and Dark Matter Experiments  
 Speaker: D. P. Roy (Tata Institute of Fundamental Research)

Date: 3/12/07  
 Title: Jet Physics with Effective Field Theories  
 Speaker: Oscar Catà (LBNL, Berkeley)

Date: 5/12/07  
 Title: Angular distributions of B  $\rightarrow$  K l l decays  
 Speaker: Giorgi Piranishvili (University of Dortmund)

Date: 14/12/07  
 Title: Unparticles and CP-violation  
 Speaker: Roman Zwicky (Durham)

Date: 20/12/07  
 Title: Quantum Simulated Annealing  
 Speaker: S. Boixo (University of New Mexico)

Date: 21/12/07  
 Title: Universal bounds for chiral LECs from axiomatic principles  
 Speaker: Vicent Mateu (IFIC-Univ. de Valencia CSIC)





## 7. SCIENTIFIC ACTIVITIES

---

### THE EXPERIMENTAL DIVISION

During 2007 the Experimental Division's activities focused on eight major projects, most of which are long-term efforts. These projects span the fields of High Energy Physics, Astrophysics and Cosmology; and include Applied Physics research, focused on the development of Detectors for Medical Applications.

High Energy Physics is represented by three major, long-term projects:

- ATLAS, a general-purpose experimental facility at the Large Hadron Collider of CERN, the European Center for Particle Physics, which will begin operation at the startup of the LHC and will have the first useful data in 2009;
- CDF, a proton-antiproton collider experiment currently taking data at the Fermi National Accelerator Lab (Illinois, USA);
- T2K, a neutrino long base-line experiment to take place in Japan; beginning in 2009. In addition, a new project to search for double-beta decay processes in the Canfranc underground laboratory was launched.

In Astrophysics, a running experiment is being upgraded, while a new very large facility is being designed:

- MAGIC, an experiment in gamma-ray astrophysics and astroparticle physics is taking data at the Canary Islands, while complete a second telescope, to begin operations in 2008;
- CTA, a multi-telescope array to be built in the next decade, is being designed.

The Observational Cosmology program at IFAE began by joining an existing program (DES) and in 2007 by starting a new project (PAU):

- DES (Dark Energy Survey), is building a camera for a telescope at Cerro Tololo (Chile) to perform cosmology studies by observing about 300 million galaxies..
- PAU (Physics of the Accelerating Universe) is a Spanish collaboration formed under the auspices of a Consolider project, that will perform cosmology

studies by observing the Northern sky with a new telescope, which will be built in Aragon.

On the Applied Physics front, a small group continues the research initiated in 2002 with DearMama, a EU-funded project that developed a digital X-ray camera of high resolution and contrast with very small exposure of the patient to radiation. These studies are carried out in collaboration with an IFAE spin-off company, X-Ray Imatek.

### THE THEORY DIVISION

The activities of the Theory Division during 2007 fall into three broad lines: Quantum Information, Physics of Fundamental Interactions and Astroparticle and Particle Cosmology.

The Quantum Information group worked on several subjects, including: the problem of communicating information secretly to multiple recipients so that they can unveil the message only by acting collectively, and also extending the concept of Chernoff bound to quantum theory.

Research on Fundamental Interactions spanned (among others) issues of flavor physics and large  $N_c$  inspired QCD models, and in physics beyond the Standard Model, electroweak symmetry breaking in the presence of hidden sectors and the implications of a composite Higgs,

Within Astroparticle and Particle Cosmology, research dealt with effects on the Cosmic Microwave Background from a large curvature before inflation; on the long-range forces induced by a scalar particle coupled to photons; and on the phenomenological implications of leptonic forces in solar neutrino oscillations

The experimental and theoretical research activities summarized here are described in more detail in this chapter.



## 7.1 ATLAS at the CERN LHC

(Lluïsa-Maria Mir)

CERN's Large Hadron Collider (LHC) will deliver proton-proton collisions by the end of 2008, thereby opening a new energy frontier in which phenomena beyond the Standard Model of particle physics (SM) are expected to be discovered. IFAE belongs to ATLAS, one of two international collaborations that propose to exploit the full potential for new discoveries of the LHC. The ATLAS detector is 22 meters high and 44 meters long and uses novel technologies such as the large toroidal superconducting magnet system or the central pixel detector, with tens of millions of electronic channels.

IFAE strongly contributes to a broad spectrum of topics along the following lines: the Tile Calorimeter, the Trigger System, preparations for the physics analyses, preparations for the computing infrastructure and participation in the management of ATLAS.

### The ATLAS Tile Calorimeter

#### Stand-alone commissioning of the Tile Calorimeter front-end read-out electronics

The hadronic calorimeter of ATLAS, which was the very first ATLAS sub-detector deployed into the

experimental cavern, had to be commissioned sharply in time, by the first LHC collisions. In past years our group contributed to several tasks in the commissioning of the calorimeter, like maintaining the front-end read-out electronics and calibrating and monitoring the stability of the calorimeter response. Extensive quality control checks started in the second half of 2005 and continued throughout 2006. Once the final LV power supplies became available, the commissioning of the Tilecal front-end read-out electronics begun in the middle of 2006. An uncomfortable rate of failures in both the power supplies and the front-end read-out was detected immediately. To address these reliability issues a dedicated Task Force was formed in October 2006, lead by two IFAE representatives. By March 2007 the major sources of failures were identified and a list of necessary actions was drawn: the first recommendations were to enforce the quality control of the power supplies during the assembly process, to significantly enforce the burning-in period, and to enhance the power supply self monitoring capabilities. For the Tilecal front-end read-out it was recommended to fully refurbish the components involved in the LV and HV power distribution



*A small part of the Tilecal drawers were refurbished on the surface outside the ATLAS cavern. The refurbishment process is shown on the right, while the drawer insertion in the Tilecal module, using the insertion tool produced at IFAE, is shown on the left*

and to reinforce mechanically the connectors used for signal collection.

These recommendations were implemented on a 10% subset of the Tilecal read-out, and the risk of failure in this subset decreased by a factor two and five for the LV power supplies and the front-end read-out respectively.

The Tilecal front-end electronics refurbishment campaign begun in July 2007 and about 50% of the read-out components were refurbished by the end of the year. IFAE has contributed most strongly to the Tilecal refurbishment by coordinating the effort, controlling the quality of the process, and also by providing manpower and tooling. In particular, the IFAE mechanical group has designed and produced two sets of sophisticated frames to extract the Tilecal drawers from the modules in the ATLAS cavern, while preserving easy access to the electronics components. At the same time, two IFAE physicists formed a group that certified the final performance of the refurbished Tilecal read-out. This group later evolved into the present Tilecal Data Quality Monitoring (DQM) group.

#### Design and manufacturing of the calibration electronics for the whole Tilecal

Calibration electronics is another major contribution of the IFAE group to Tilecal. This system was designed to read either the PMT currents produced by the  $Cs^{137}$  sources or the “Minimum Bias” currents produced in ATLAS by low transverse momentum interactions. After the installation of ATLAS in the experimental cavern, and throughout the life of the experiment,  $Cs^{137}$  sources will be inserted into the Tile calorimeter during periods without beams. This will allow to perform the initial inter-calibration of the entire calorimeter, and to maintain the calibration by monitoring the changes in the response of any readout cell. Furthermore, monitoring Minimum Bias currents during data taking provides real-time information on the calorimeter performance, and may even allow real-time relative instantaneous luminosity monitoring. Calibration and monitoring tasks in Tilecal are controlled by a board designed at IFAE. Six such VME-based, ATLAS-Tile interface boards, called SHAFT, were produced by IFAE in 2006. The stand-alone commissioning of the integrator-based calibration system had continued

through 2007, concentrating on the internal calibration of the system with few hundred calibration runs taken and analyzed, and on studying the performance stability. IFAE has contributed strongly to the organization of the Tilecal calibration workshop in November 2007, where the above studies were summarized. The integrator-based monitoring system was also fully integrated into the ATLAS TDAQ system by the end of 2007.

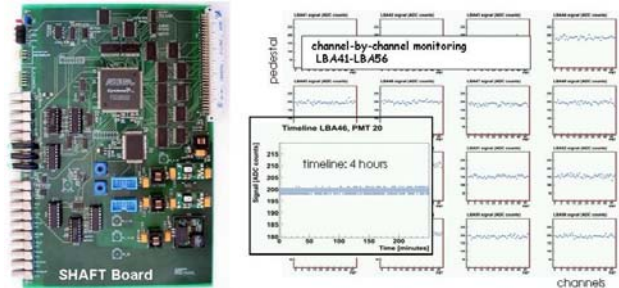

*Top layer of the 6-layers SHAFT board, designed and built at IFAE (left), and example of monitoring of the stability of the PMTs of one of Tilecal module.*

#### Monitoring of the Tilecal performance at the High Level Trigger

In 2007, cosmic ray data have been regularly recorded, both in Standalone Tile Calorimeter mode and in combination with the Liquid Argon calorimeter or the Muon system. A detailed monitoring program has been developed by our group to run online during cosmic rays data taking. This monitoring system is needed to verify the goodness of the data quality to be sent to permanent storage. In the ATLAS data acquisition and data flow, the Event Filter receives completely assembled physics events from the Sub-Farm Input (SFI). Data is transmitted by the Event Filter Data Flow (EFD) to Processing Tasks (PT), where trigger algorithms run. The EF is therefore the natural place to perform the monitoring of high level physics quantities and the cross-checks among different detectors. The key feature of the EF monitoring is its capability of providing data quality checks even before data is stored to disk. The EF segment, controlled remotely by the DAQ system, is running on a dedicated node, so that PT processes don't share resources with other DAQ subsystems. Several PTs are started sampling events from different SFI nodes, in order to accumulate statistics in the merged histograms.

The Tilecal Event Filter Monitoring has been completely developed and validated by IFAE members and successfully integrated in the ATLAS DAQ during the commissioning phase. In particular, it has been tested and extensively employed during the commissioning of Tilecal during the 2007 combined readout data taking periods, when larger and larger parts of the ATLAS detector were read out, aiming at recording the passage of muons of cosmic origin. Aspects of the muon signal, ranging from the readout channel level to quantities related to completely reconstructed muon tracks, have been monitored.

The final goal of the Tilecal Event Filter monitoring system is to build a set of monitoring histograms allowing the shifter to assess the quality of the recorded data and to give an overview over the operation of the whole detector. Regions with unusual activity can be promptly identified up to the detail of the individual read-out channel and the corresponding information is passed to reconstruction experts. In particular, malfunctioning detector parts can be quickly identified and taken into account in the definition of the detector conditions during the data taking. The Tilecal monitoring system also implements a set of reference histograms and raises an alarm automatically if a monitored observable deviates significantly from its reference.

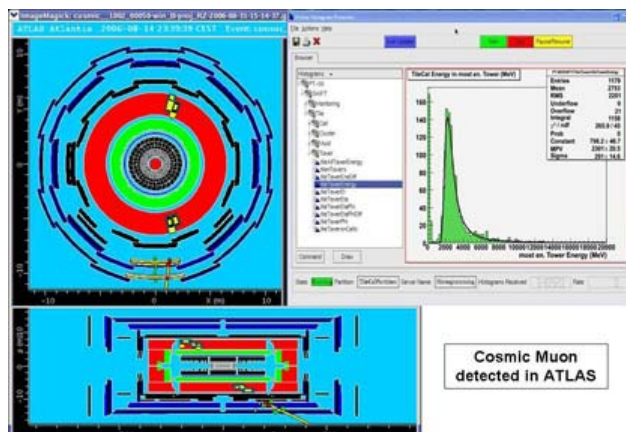

*ATLAS Event Display showing a cosmic ray going through the detector (left) and energy deposited by cosmic muons in the Tilecal calorimeter (right)*

### Timing calibration of the Tilecal read-out with cosmic muons

During 2007, IFAE has developed a novel method to synchronize Tilecal read-out using physics events. Such synchronization is crucial for the performance of the Optimal Filtering algorithm that reconstructs online the energy amplitudes with a resolution proportional to the uncertainty in the timing measurement. The method is based on the comparison between the expected time of flight of muons crossing Tilecal cells and the measured time in each of the cells. The method has been successfully validated using muons of cosmic origin in September and October of 2007, and a 0.7 ns uncertainty in the Tilecal timing was reached, which is sufficient for the Optimal Filtering algorithm to reach about 1% uncertainty in the reconstruction of the signal amplitude.

### **The ATLAS Trigger System**

#### Event Filter Infrastructure

In the framework of the ATLAS software, IFAE contributes to the High Level Trigger (HLT). The HLT is a software-based trigger running in a computer farm of about 1500 processing nodes. Its algorithms are designed to reduce the event rate down to ~200 Hz for events of size ~1.5 Mbyte. IFAE contributes to different aspects of the HLT, from algorithm performance studies to implementation and testing in the online computer farm.

The HLT is structured in two levels, called Level-2 and Event Filter (EF). The EF uses many components of the offline event reconstruction and physics analysis. It provides the final selection of physics events and streams them to mass storage.

In the EF, the flow of events and their processing are handled by two major software components, the Event Filter Dataflow and the Processing Tasks (PT), which run in every processing node of the farm. IFAE is in charge of all software components related to the PT. The main role of the PT is to serve as interface to the execution of the trigger algorithms. In 2007, several alternative versions of the PT software, enforcing routing and streaming of the data to different files, were discussed. IFAE

implemented the chosen version, which is going to be tested in 2008 before data taking starts up.

Besides the main event triggering and data transportation functions, the EF also implements monitoring of the selection process and the detectors. IFAE has completed the different components of the monitoring system, including the gathering of the histograms implemented in EF among the different racks. We have also implemented an EF plug-in, allowing EF information to be monitored and displayed to the online shifter in a coherent way. Our group also contributed to the installation and commissioning of the EF nodes in the ATLAS farm as well as to control room shifts.

### Trigger Operations and Integration Tasks

A new managerial structure of the ATLAS experiment has been implemented to better prepare for the physics data taking period foreseen in 2008. In particular, an overall ATLAS Trigger group has been created in 2007. One of the members of IFAE has been made responsible of the overall organization of the trigger operations of ATLAS, including Level-1 and High Level Triggers. This responsibility implies the organization of the shifts structure for all trigger aspects, going from the core trigger software to the online shift monitoring. In parallel to this, another member of IFAE is co-coordinating the integration of the HLT algorithms and making sure that the well-tested algorithms in the ATLAS offline framework are properly working in the online environment too. This step is very important and necessary to have a fully functional trigger when data taking starts up. The tool emulating the EF online functionality, responsibility of IFAE since its design, has been rewritten during 2007 in order to ease its future maintenance. IFAE has also taken a big role in all the technical trigger preparation runs in the ATLAS online farms that have taken place in 2007. The experience accumulated in that work will be directly useful for the physics analysis of the first ATLAS data and the searches for new physics.

### Level-1 and Level-2 Tau trigger studies

IFAE not only contributed to the online aspects of the trigger software, but it also contributed to the

performance and optimization of the trigger algorithms. Of particular importance is the tau trigger, since the tau lepton is one of the favored decay products of many predicted new particles.

The Level-1 tau trigger selection in ATLAS is based on electromagnetic and hadronic calorimeter information, and uses trigger towers of approximate size  $\Delta\eta \times \Delta\phi = 0.1 \times 0.1$ . The trigger algorithms consider rectangular Regions of Interest of  $4 \times 4$  towers in both calorimeters and make use of different elements, each formed by summing the transverse energy over a group of towers. The IFAE group has explored possible reconstruction methods of the tau, optimizing the selection criteria for the Level-1 tau trigger and studying its performance in terms of calibration and energy reconstruction. The energy reconstructed with the standard algorithm (*TauCluster*) has been compared with other reconstruction methods. The effect of different energy reconstruction methods to the Level-1 efficiency as a function of the offline transverse energy is shown in the figure. The curve for *TauCluster* is systematically above the others proving that this provides the best selection for the Level-1 tau trigger.

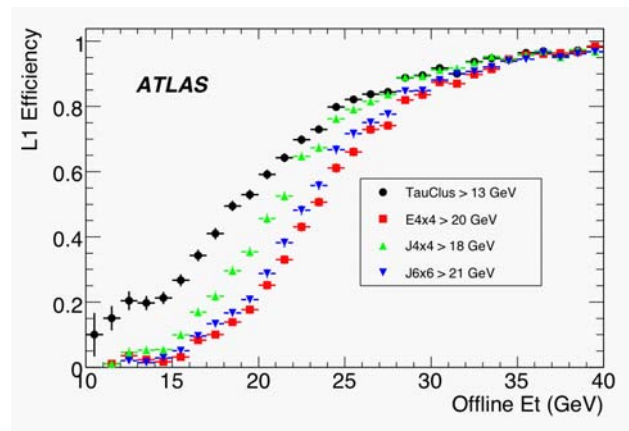

*Trigger efficiency curves for different Level-1 energy reconstruction methods as a function of the offline transverse energy.*

The Level-2 tau trigger allows the refinement of the Level-1 tau trigger candidate with full granularity in the calorimeters, as well as the inclusion of tracking information from the Inner Detector. The IFAE group is responsible for the maintenance of the software package for the tau reconstruction in the

calorimeters. Recently the focus of the work has been on providing the selection strategy and studying the system performance. Next figure shows the Level-2 tau trigger efficiency relative to Level-1 for different tau energy thresholds with respect to the true visible transverse energy.

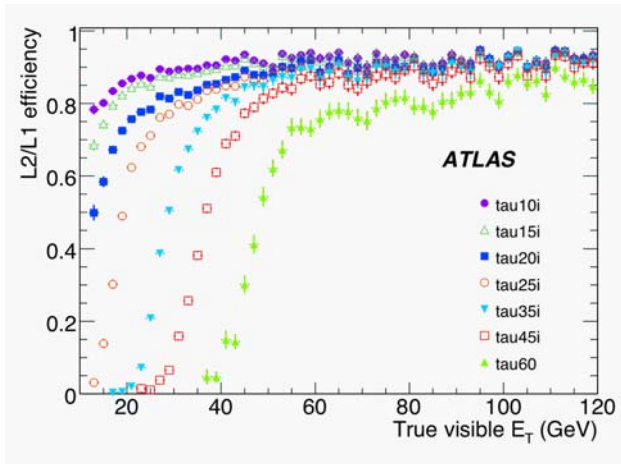

Efficiency curves of Level-2 tau selection relative to Level-1 for different tau energy thresholds.

### Tau trigger efficiency from data study

In order to understand how the tau trigger efficiency can be estimated using real data, a study using semi-leptonic top-pair events has been started. Different Monte Carlo samples, including signal and background, have been used. A “tag and probe” method has been applied, where four jets are identified and used as tag, while the tau lepton is used as probe and its efficiency calculated

The experience accumulated in the different studies of the tau trigger performance will be directly applied to the physics analysis of the first ATLAS data and the searches for new physics.

### **The ATLAS Physics Program**

The LHC will provide excellent opportunities to search for physics beyond the SM, in particular for supersymmetry (SUSY). If supersymmetric particles indeed exist and are not very massive they will be produced in sufficient amount at the LHC for them to be discovered. But before any claim of discovery

can be made, one must be sure that all backgrounds are well understood and under control. There are at present many uncertainties in the properties and cross-sections of the standard processes at the LHC energies, and it is not expected that Monte Carlo (MC) predictions will achieve the required precision. Thus the determination of these cross-sections and properties should be obtained from data.

Among all the SM processes, Z-boson plus jets and top-quark pair-production might be dominant backgrounds for many SUSY searches. Two analyses are being developed at IFAE: Z+jets and tau semileptonic top-pair decays. The idea is to determine the production cross-sections first, and to quantify their contribution as backgrounds to SUSY afterwards.

Final states containing  $Z(\rightarrow e^+e^-, \mu^+\mu^-) + \text{jets}$  are characterized by the presence of an energetic pair of leptons plus several jets. On the one hand, the existence of additional jets tends to boost the Z, and thus the decay leptons, to higher transverse momentum leading to a larger acceptance. On the other hand, the presence of jets will affect negatively the isolation of the leptons. The combination of the two effects will lead to final efficiencies which are in general a few percent lower than those of inclusive analyses.

The comparison of the cross-section measurements in data with theoretical predictions should be done at hadron level. Therefore, data have to be unfolded to parton level, or the theory corrected hadron level; in the later case the theoretical predictions have to be corrected with respect to the non-perturbative effects of fragmentation and underlying event. These corrections are obtained using MC simulation. The Z+jets cross-section is measured as a function of the jet transverse energies and multiplicity, and compared to LO and NLO perturbative QCD predictions. As an example, we can see the transverse energy of the leading jet and the number of events for Pythia and Alpgen MC generated events along with predictions from MCFM.

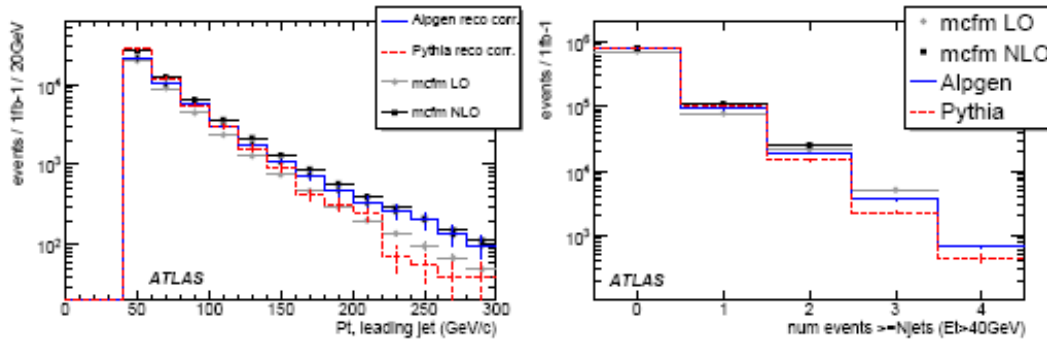

Unfolded transverse energy of the leading jet (left) and number of expected events at hadron level (right) in Pythia and Alpgen  $Z(\rightarrow\mu^+\mu^-) + jets$  Monte Carlo, shown along with predictions from MCFM for an integrated luminosity of  $1 \text{ fb}^{-1}$ .

From the above figure we conclude that Pythia and Alpgen distributions can be clearly distinguished and data will tell us which one gives a better modeling of nature. The dominant systematic error in the cross-section measurement will be due to the uncertainty in the jet energy scale, which at least during the first two years of running, will dominate

over the parton distribution functions theoretical uncertainty.

The main aim of the top analysis is to explore the  $t\bar{t} \rightarrow W(qq')W(\tau_{had}\nu)b\bar{b}$  channel exclusively to understand the importance of this process as a background to SUSY processes with no leptons.

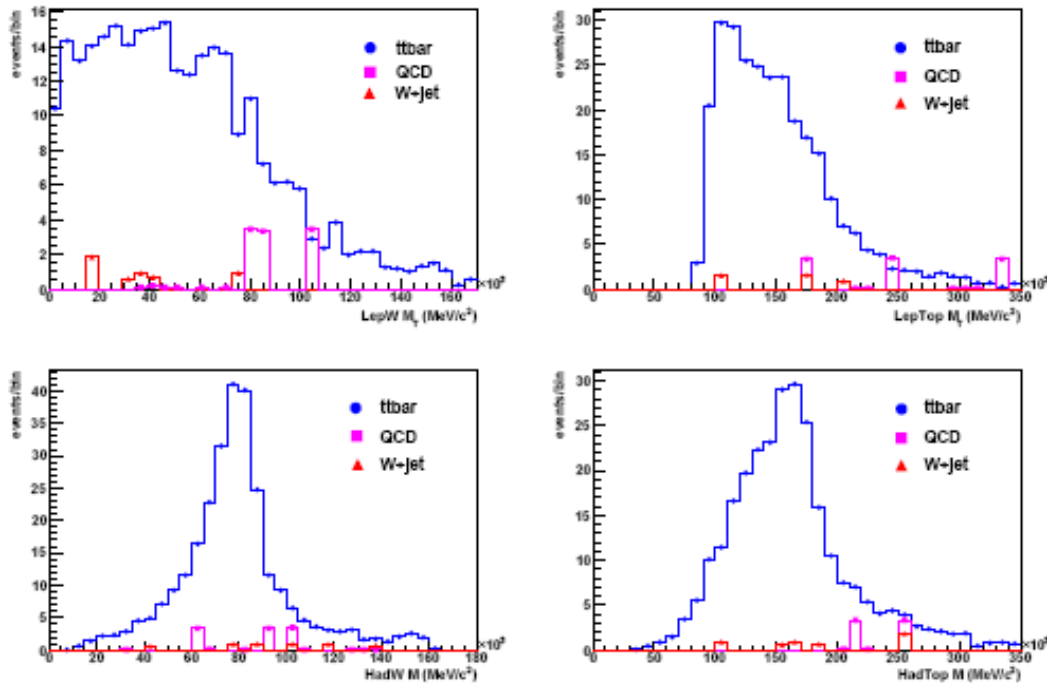

Top: leptonic  $W$  (left) and top (right) transverse masses. Bottom: hadronic  $W$  (left) and top (right) invariant masses. The plots correspond to an integrated luminosity of  $100 \text{ pb}^{-1}$ . Signal is shown in circles, QCD background with squares and  $W+jets$  background with triangles.



Through the measurement of its cross-section, one may then evaluate the expected number of these events in the SUSY region, which is characterized by large values of the missing transverse energy. Furthermore, this analysis will complement other tau reconstruction and identification studies performed in cleaner environments, and will also play an important role in the commissioning of the tau trigger.

The topology of the  $t\bar{t} \rightarrow W(qq')W(\tau_{had}\nu)b\bar{b}$  events consists of one tau, two light-quark jets and two b-jets. Since the jet multiplicity is high, a large rate of jets misidentified as taus would imply large combinatorial background. To avoid this type of background and also background from the other two semileptonic  $t\bar{t}$  decays, a lot of effort has been put to use a tau identification algorithm with both high selection efficiency and high jet and electron rejection. B-tagging is obtained combining impact parameter and secondary vertex information. With the present selection a signal-to-background ratio of the order of 15 can be achieved. The two studies have used realistic simulations of the ATLAS trigger capabilities and reconstruction efficiencies of leptons and jets. The analyses have been included in the Computing System Commissioning notes that are going to be published as the ATLAS physics reference book.

### Computing Infrastructure

Thanks to the FPA2005-07688-C03 and FPA2007-66708-C03-02 projects funds from the Spanish government, IFAE is building the infrastructure needed to perform the analysis of data foreseen in the coming years, once the data taking period starts. It is responsibility of IFAE to operate a Tier2 centre of analysis and Monte Carlo simulation, in a distributed way, in collaboration with IFIC in Valencia and the UAM in Madrid. IFAE's Tier2 is located near the Tier1 PIC facilities, sharing some of their basic services but keeping its management independent.

The main use of Tier2 centres is the massive production of simulated data, together with the analysis of both real and simulated data. Furthermore, Tier2 personnel participate in the operational tasks of the computer infrastructure of ATLAS and of the ATLAS subdetectors, thus fulfilling the requirements specified in the Computing Technical Design Report of ATLAS.

IFAE Tier2 personnel also provide direct user support to ATLAS IFAE physicists, building the infrastructure of interactive analysis known as Tier3.

The performance of the IFAE Tier2 with respect to the obligations derived from the Computing Memorandum of Understanding (cMoU) during 2007 has been excellent, doubling the computing power required by the cMoU (297.920 kSI2k-hours provided versus the 146.577 kSI2k-hours pledged). Also the availability and reliability of IFAE Tier2 have been evaluated by an external organization with a result of 93 and 95% respectively, very close to the 95% value required by the cMoU.

### Participation in the management of ATLAS

Several members of the group have been contributing to the management of the collaboration, to the decisions on technical relevant topics for the whole experiment, and to evaluation committees of dedicated task forces:

- ▶ M. Bosman: member of the ATLAS Speakers Committee, member of the ATLAS Collaboration Board Chair's Advisory Committee, and co-convenor of the ATLAS top quark physics working group.
- ▶ I. Korolkov: member of the Tile Calorimeter Institute Board, Tilecal representative to the ATLAS Luminosity Task Force, Tilecal representative to the ATLAS SLHC upgrade task force, and member of the Tilecal Speakers Committee.
- ▶ I. Riu: Co-convenor of the ATLAS TDAQ Online Integration Group and member of the TDAQ Institute Board.
- ▶ C. Padilla: Coordinator of the Trigger Operations Group.



# 7.2 The Collider Detector at the Tevatron (CDF)

(Mario Martinez)

At the Tevatron, proton-antiproton collisions are produced with a center-of-mass energy of 1.96 TeV. After the discovery of the top quark in 1995, the Tevatron has been upgraded: the center-of-mass energy has been increased (from 1.8 to 1.96 TeV) and its instantaneous luminosity has already achieved the Run II design value of  $2 \cdot 10^{32}/\text{cm}^2\text{s}$ . The Tevatron has already delivered a total integrated luminosity above  $3\text{fb}^{-1}$ . CDF has also gone through major upgrades. A new DAQ and trigger systems have been installed (where the latter includes an original setup which allows the detection online of secondary vertices), together with a new tracking chamber, new silicon tracker, a time-of-flight detector, new forward calorimeters and increased angular coverage for muon detection. The experiment has already collected about  $2700 \text{ pb}^{-1}$  (about twenty seven times more luminosity than that integrated in Run I) and it is expected to collect at least  $6 \text{ fb}^{-1}$  by the end of the Run II.

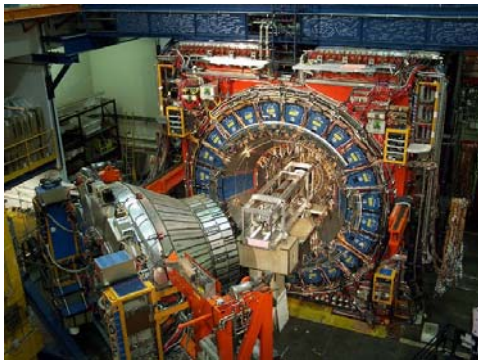

Picture of CDF during the installation of the Silicon Detector into the tracking chamber

### DQM: data quality monitoring of the CDF data

The IFAE group in CDF has major responsibilities on quality monitoring (DQM) of the data used by CDF for physics analyses. The quality control is performed at two levels. Online, an automatic

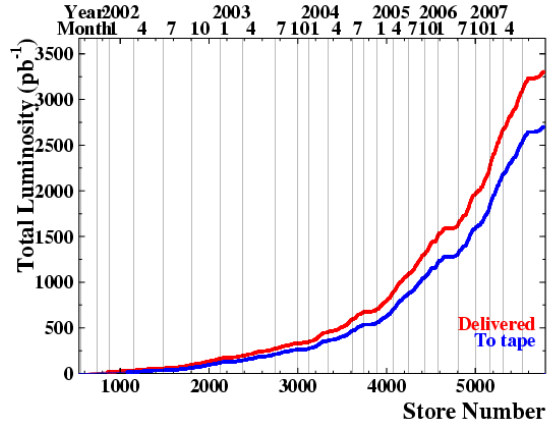

Total delivered and on-tape luminosity (updated: December 2007)

system alerts the CDF shift crew if faults are observed in the data. The online system is based on JAVA monitors that control the basic performance of the detector. The online diagnosis is available via Web and finally kept in ORACLE databases. Offline, after the data has been processed, a DQM system automatically checks the quality of the data using very high level physics objects (electrons, photons, muons, J/Psi, jets, etc) which, in addition to confirming the online diagnosis, detects possible errors introduced in the offline reconstruction codes or calibration constants. The final DQM decisions are used to establish standard «good run» lists for the whole collaboration.

The DQM project requires a good knowledge of CDF, both the hardware of the different detectors and the offline reconstruction software. Moreover, the DQM activities involve a rather high level of initiative and coordination within CDF, which put IFAE members in a very visible position inside the collaboration. The DQM is considered in the CDF organization chart as one main «detector subsystem» and two IFAE members act as coordinators of the offline data validation activities.

## Physics program of the IFAE group in CDF

The strength of the group in physics analyses was again demonstrated in 2007 with 13 communications in workshops and conferences, including a plenary talk at the Lepton-Photon conference in Korea, considered the most important international conference in the field. Two PhD students from the group defended their theses in spring of 2007 and now continue their scientific careers with first-class research associate positions in USA and Germany. Finally, during 2007 two members of the IFAE group acted as conveners of the QCD and SUSY physics groups in CDF, as one of our members acted as CDF Operation Manager (Run Coordinator).

- **Measurement of the inclusive jet cross section at CDF using the  $K_T$  algorithm**

In Run II, the measurement of the inclusive jet cross section is a fundamental piece of the Tevatron physics program. Thanks to the increase in the center-of-mass energy, the jet cross section has increased by a factor about 3 for jets with transverse energies above 500 GeV and the new measurements extend the kinematics region of the transverse energy of the jets up to values of about 700 GeV (corresponding to distances of the order of  $10^{-19}$  m). The increase in the Tevatron luminosity makes possible to perform a precise jet measurement sensitive to the presence of new physics.

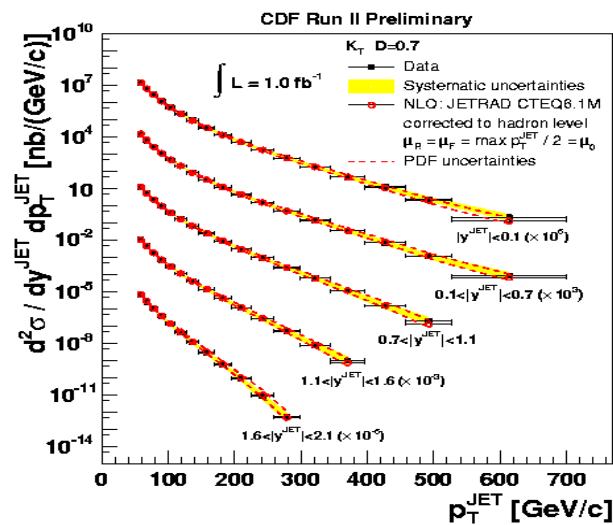

Measured inclusive jet cross section using the  $K_T$  algorithm.

The IFAE members have carried out the analyses with jets reconstructed using the  $K_T$  algorithm at CDF. Final results, for central and forward jets, and using up to  $1\text{fb}^{-1}$  of Run II data, have been published in Physical Review Letters and Physical Review D. The results indicate a good agreement with NLO pQCD calculations and confirm the validity of the  $K_T$  algorithm to search for jets of hadrons in hadron-hadron environments. The jet studies required dedicated measurements on jet shapes that were published in Physical Review D.

- **Search for Squarks and Gluinos**

The search for new physics beyond the standard model and, in particular, supersymmetry, is one of the main goals of both the Tevatron and the LHC physics programs. At the Tevatron, the best sensitivity to the production of supersymmetric particles comes from the study of hadronic final states with multiple jets and large missing transverse energy. These topologies could correspond to the production of squarks and gluinos which decay producing cascades of gluons and quarks, which are detected as multiple jets in the final state. For those models where R-parity is conserved, the LSPs (Lightest Supersymmetric Particles) are expected to be stable and leave CDF undetected, producing a signal of large missing transverse energy.

Results have been obtained based on  $1.4\text{fb}^{-1}$  of Run II data (see Figures below). The analysis was optimized in different regions in the gluino/squark mass plane. After selection cuts, no evidence of new physics is observed yet. The results extend Run I exclusion limits on squark and gluino masses significantly and have been presented at several international conferences. The analysis is being now extended to a  $2\text{fb}^{-1}$  data sample and results will be submitted to Physical Review Letters.

The inclusive analysis is being complemented by a search for super-symmetric partners of bottom and top quarks, particularly light in SUSY scenarios at large  $\tan\beta$ , and will require the identification of b-quark jets. More data and a complete scan of parameter space will either discovery SUSY or impose very stringent limits to the masses of squarks and gluinos.

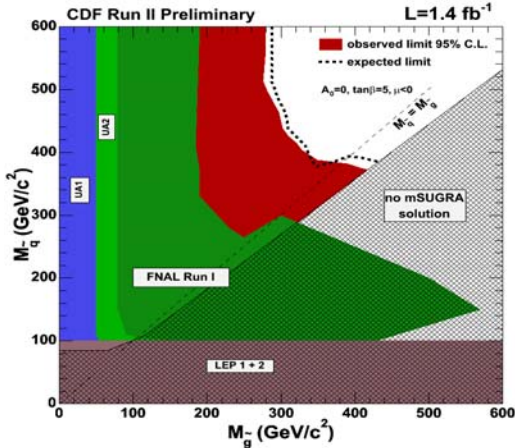

Squark/Gluino exclusion plane. The red band indicates the results from this analysis.

• Study of Z+jets Final States

In 2005, the group opened a new line of analysis with detailed studies of jet production in events with a Z boson in the final state. Precise measurements on Z+jets production constitute a fundamental test of pQCD and provide a clean sample to validate Monte Carlo predictions for background estimations in searches for new physics. Preliminary studies, presented at several conferences, indicated that a good understanding of the hadronic final state in Z+jets production has been already achieved in the current Monte Carlo implementations. Measured cross sections, based on 1.7fb<sup>-1</sup> of data, have been compared to pQCD NLO predictions. The results have recently been published in Physical Review Letters.

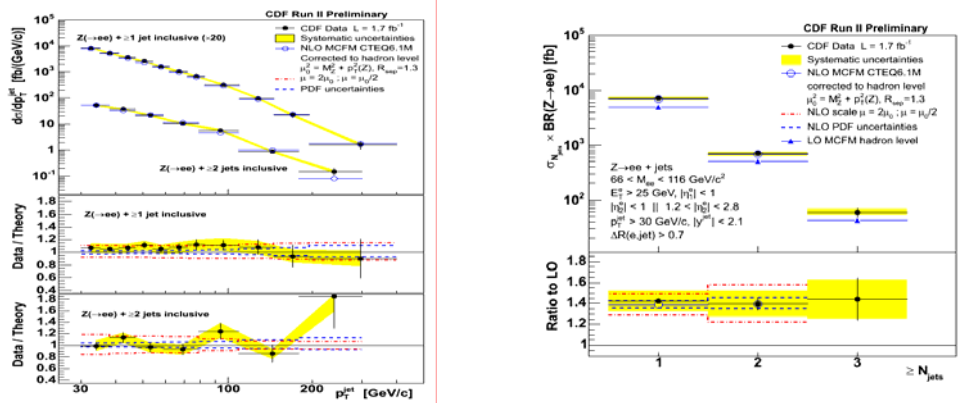
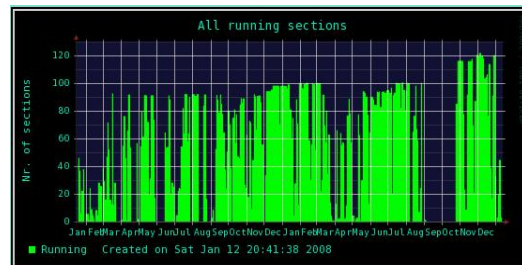

Figure: Measured Z + jets Cross Sections compared to pQCD NLO prediction.

• BCNCAF cluster in Barcelona

The IFAE group decided in 2003 to use the PIC (Scientific Information Port) in Barcelona to install a computer cluster dedicated to the analysis of the CDF data. The infrastructure available at PIC allows establishing (with relatively low costs) a robust computer cluster devoted to the analysis of Tevatron data. During 2007, the size of the computer cluster has been steadily increased and it has already played a significant role in the generation of the necessary Monte Carlo samples for the physics analyses carried out at Barcelona. The CAF has been used by the rest of the Spanish community in CDF and it has

been opened to general use for centralized Monte Carlo generation by the whole experiment.



Usage of BCNCAF during the last 24 months.



## 7.3 Neutrino Experiments at IFAE

(Federico Sánchez)

---

The announcement of the discovery of neutrino oscillations in atmospheric neutrinos, made by the Super-Kamiokande collaboration in 1998, revived the interest in neutrino physics and in particular stimulated many new experiments which aim at elucidating the oscillation phenomenon. Super-Kamiokande also confirmed the "deficit" in the observation of solar neutrinos reported by many previous experiments. The final proof that this deficit is also due to neutrino oscillations was given by the SNO collaboration in 2002. These results imply that neutrinos have mass, albeit a very small one. The fact that the neutrinos have very small masses compared to their partners (leptons) in the Standard Model has stimulated novel theoretical developments. The neutrino group at the IFAE is contributing to two aspects of the neutrino experimental program: the measurement of the neutrino oscillation parameters at K2K and T2K, and the nature of the neutrinos with neutrino-less double beta decay experiments.

### The K2K and T2K Neutrino Oscillation Experiment

In K2K an intense muon neutrino beam is detected at two locations: a Near Detector (ND) located 300 m downstream of the production point in KEK, and a far detector, Super-Kamiokande (SK). SuperKamikande consists of a large tank containing 50,000 tons of very pure water. Neutrino-muon interactions are detected and identified by the Čerenkov light generated by the muons produced in the interaction. This light is collected in the array of photomultipliers that cover the outer surface of the water tank. The oscillation parameters are obtained comparing the flux and the energy distribution of the neutrinos detected at the near and the far detectors.

The activity of the IFAE group was centered on the Near Detector, and in particular in a sub-detector named SciBar, installed in the summer of 2003. IFAE members have contributed to the analysis of several neutrino-nucleus interactions: single charged pion production, coherent charged pion production, multipion charged current production and measurement of the axial-vector form factor of the

charged current quasielastic. F. Sánchez has been the physics coordinator of the SciBar analysis since 2006. The SciBar detector has demonstrated its potential for studying low-energy neutrinos. The detector has been approved to run at the Mini-Boone neutrino line at Fermilab, to study neutrino interactions below 1 GeV, (see SciBooNE Collaboration. FERMILAB-PROPOSAL-0954 and hep-ex/0601022). The project started at the end of 2006 with a small contribution from the IFAE neutrino group, that is in charge of the development of the software and reconstruction code. IFAE is also contributing to the analysis of the data following the experienced acquired at the K2K experiment.

The neutrino oscillations can be described by a mixing matrix (three angles plus an imaginary phase) between neutrino mass and flavor states plus two mass-squared differences between neutrino mass states. Atmospheric neutrinos and the K2K experiment give information on  $\theta_{23}$  and on the mass-squared difference between neutrinos. Solar neutrino experiments are consistent with the oscillation of electron-neutrinos into the other two species, and give information about the mass difference between the two mass states 1 and 2, and the mixing angle  $\theta_{12}$ . To complete the puzzle, it is necessary to know the value of the other mixing angle,  $\theta_{13}$ , which is known to be small. The best option to measure this angle would be the observation of the transition of muon-neutrinos into electron-neutrinos. This is the principal aim of the T2K experiment. A Letter of Intent (LoI) was submitted to the Japanese authorities, and the experiment was approved in 2004. The IFAE team signed the LoI (<http://neutrino.kek.jp/jhfnu/loi/loi.v2.030528.pdf>), together with other 12 European groups. The final proposal of the experiment was submitted in April of 2005. In T2K a beam of neutrinos, twenty times more intense than that of K2K, will be sent from Tokai, Japan, where the J-PARC 50 GeV proton accelerator is being constructed, to SuperKamioKande, 300 km away. The aim is to find for the first time the appearance of a different neutrino flavor (electron neutrinos) in a beam of muon neutrinos.

The European groups contribute significantly to the Near Detector (ND). The ND is a multipurpose detector located a 280 m from the proton target where the neutrinos are produced. This detector must measure the neutrino flux and study neutrino interactions from a beam with a spectrum similar to the one observed at Super-Kamiokande. The baseline design of T2K utilizes the UA1 magnet to provide a moderate magnetic field (0.2T). The detection devices are divided into two sections, one (called POD) dedicated to detecting neutral pions and another optimized to detecting and measure the momentum of charged tracks. The tracking section is composed of two Fine Grained scintillator Detectors (FGD), similar to SciBar, and three Time Projection Chambers (TPC) measuring the track momentum. The TPCs surround the FGD blocks to measure any charged track produced in the scintillators.

The Barcelona group in T2K focuses on the following lines of work:

1. Collaboration on the development of the reconstruction code for the ND280 detector with special emphasis on track reconstruction and fitting. One of us (F. Sánchez) is coordinating the reconstruction group in T2K.

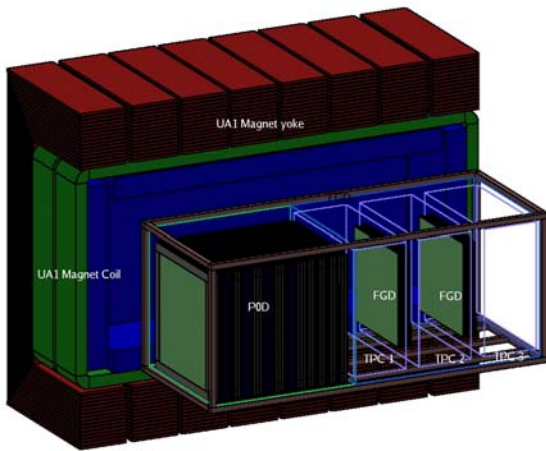

Sectional view of the ND280m detector, showing the components. The neutrino beam enters from the left.

2. The IFAE neutrino group has also started the design of the control and monitoring system for the operation of the ND280 Magnet. The system has to be installed in Japan in March 2009.

3. IFAE is involved in the development, in collaboration with the University of Geneva, of the test bench where all TPC sensors (MicroMegas) will be tested and calibrated before being installed in the final detector. IFAE took the responsibility of the data acquisition and analysis tools, and has also contributed to the design and commissioning of the gas system. The test consists on a radioactive source ( $^{55}\text{Fe}$ ) which is placed in front of each of the readout units at a time and measures the channel gain and energy resolution. During September and October of 2007, IFAE collaborated in the test of a MicroMega prototype at CERN using the electronics to be used at the final installation. IFAE also collaborated to the analysis of the data.

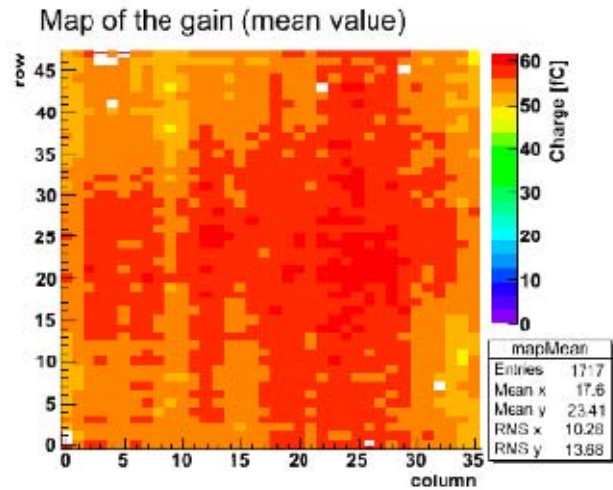

MicroMega gain uniformity obtained with the Test Bench at CERN. The observed non-uniformity is of the order of 10% and it is explained from the capacitance of the readout lines.

4. IFAE is also in charge of the design and construction of an electronic board to emulate the front-end electronics of the TPC readout. This board will be use as a quality check during the production of the readout electronic boards.

The full detector will be installed in April 2009, coinciding with the first neutrino beam.



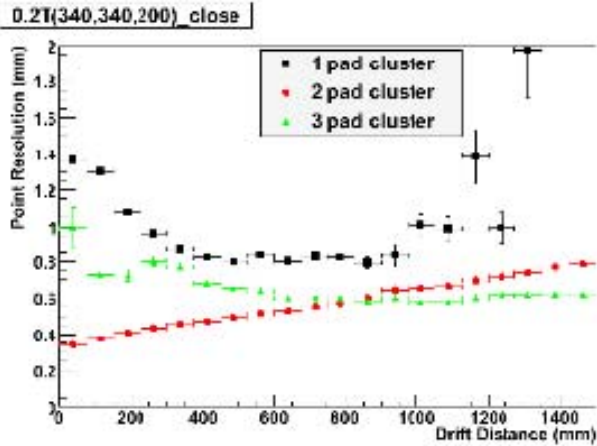

Point resolution obtained with a MicroMega prototypes at CERN. The resolution is shown for clusters with one two or three readout channels.

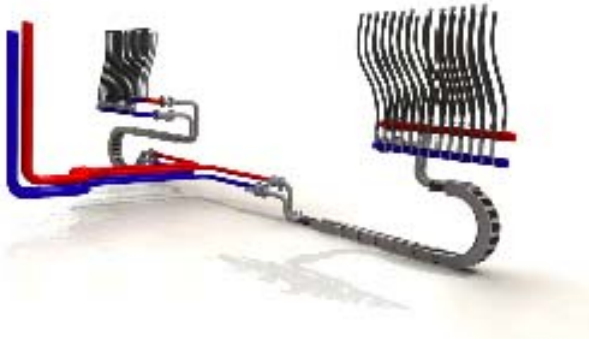

Cooling water distribution system for the ND280 magnet, being designed and constructed at the IFAE.

## Double Beta Decay Experiments and the Underground Physics in Canfranc

The recent construction of a new experimental hall in the Canfranc underground laboratory (LSC), near Jaca, opens up exciting opportunities for neutrino physics in Spain. This new hall, located at a depth of 2500 m water equivalent (about the same depth as SuperKamiokande in Japan) offers a surface of about 600 m<sup>2</sup>. IFAE has been involved in the exploration of different experimental options for this laboratory. Among the different options considered, the IFAE neutrino group joined the SuperNemo/Nemo collaboration to evaluate the performance and the potential of the SuperNemo experiment in Canfranc. The IFAE neutrino group

collaborated with the IFIC in coding the simulation and reconstruction software. SuperNemo would be the continuation of the NEMO experiment [1], currently taking data in the underground laboratory of the Frejus tunnel, near Modane, France. The experimental technique used by NEMO differs from conventional  $\beta\beta$  experiments. Most of the current generation experiments are based on calorimetric detectors, where a double beta emitter crystal with very good calorimetric resolution such as Germanium (Ge) acts simultaneously as a source and as a detector. This technique profits from the excellent energy resolution of Ge, which allows the observation of a narrow peak in the end-point distribution of the  $\beta\beta 0\nu$  spectrum. The disadvantage is that the only signature to reduce background is the sum of the energies of the two electrons. A second disadvantage is that the experiment is limited to a single type of material. On the contrary, the technique developed by the NEMO experiment consists in separating the source (which is inserted, as a very fine foil in the middle of the detector) from the detector itself, which is made of a tracking volume surrounded by a calorimeter. Thus, one measures the track and charge of the two electrons arising from the decay and their energy in the calorimeter. The advantage of the NEMO technique is that external backgrounds due to natural decay chains are very efficiently suppressed. In addition, one can use many different sources by changing the foil. The disadvantage of NEMO is that one cannot use crystals as calorimeters resulting in a very poor energy resolution of 10% to be compared with the 0.1% obtained with Germanium like detectors.

From this experience, the group of IFAE together with IFIC and University of Zaragoza embarked in a new project called NEXT (for NEutrino Xenon TPC) to combine the advantages of both approaches. The idea is to use a Time Projection Chamber filled with xenon gas enriched with isotope  $^{136}\text{Xe}$ . The idea was implemented in the past in a very small prototype with very encouraging results [2]. The  $^{136}\text{Xe}$  is a double beta emitter with attractive properties:

1. the energy of the two emitted electrons is 2.48 MeV, well above most of the natural radioactivity and high enough to obtain a good energy resolution.
2. the Xe is a noble gas that can be used as detector. Therefore radioactive source and detector physically coincide, as with Ge detectors. This eliminates one

of the main handicaps of NEMO - like detectors as described above. The intrinsic resolution has been measured to be around 1% FWHM with 600 KeV gammas (i.e. 0.5% FWHM at 2.5 MeV).

3. Using a gaseous detector it is possible to separately detect the two electrons, thereby reducing the external background from neutrons and gammas. The electron will be seen as a long track with large energy deposition blobs at the edges. One may define a fiducial region in the center of the detector to reduce background coming from the apparatus walls. The gas can be re-circulated and purified reducing the accumulation of radioactive background.

4. The lifetime of the double beta decay with neutrinos is not yet measured but the measured limit is very high. This property of the  $^{136}\text{Xe}$  reduces the contribution of this irreducible background.

The IFAE neutrino group efforts have focused on the design of a TPC prototype (see figure) to allow testing several readout technologies at high gas pressures. IFAE has also contributed to the Monte Carlo simulation, event reconstruction and gas properties studies.

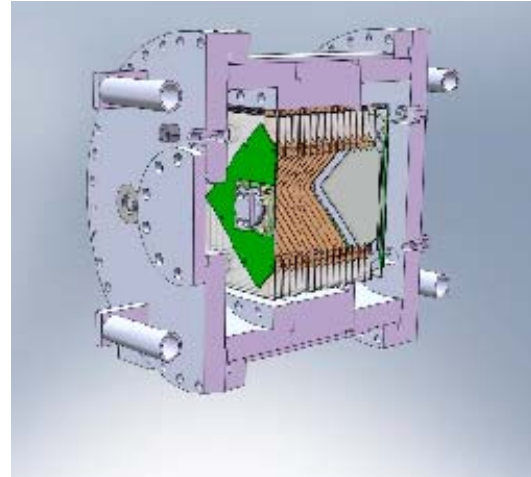

*TPC prototype designed at IFAE for test of readout technology for the NEXT project. The TPC will be able to hold 10 atm.*

[1] R. Arnold *et al.*, "Technical design and performance of the NEMO 3 detector", Nucl. Instrum. Meth. A 536 (2005) 79

[2] H T Wong *et al* 1991 *J. Phys. G: Nucl. Part. Phys.* 17 S165-S172

## 7.4 The MAGIC Telescopes

(Juan Cortina)

---

MAGIC is the acronym of Major Atmospheric Gamma-ray Imaging Telescope. The telescope is located at the Roque de los Muchachos Observatory in the Island of La Palma of the Canary Islands (28.8 N, 17.9 W, 2200 m altitude). The goal of the experiment is the study of the very high energy gamma radiation arriving to Earth from a relatively small number of sources. This study gives information on the mechanisms that produce such radiation, the most violent known in the cosmos. Furthermore the propagation of the radiation over cosmological distances is sensitive to the geometry and matter contents of the cosmos itself. MAGIC detects the light induced by the interactions of the incoming gamma rays with the upper atmosphere.

This light is reflected onto a segmented mirror of 17m diameter and collected in the camera, located at the focal point. The camera is provided with very fast and sensitive photo-detectors.

The IFAE group, at the time led by M. Martínez, built the camera of the telescope and its control system, as well as the building which houses the electronics and data taking equipment. In addition IFAE was in charge of the overall control of the telescope. The telescope was inaugurated in October 2003 and was commissioned during 2004. In 2007 the telescope entered its third year of regular observations.



*An artist's view of the X-ray binary Cygnus X-1, a system of a supergiant star and a stellar-mass black hole. Researchers at IFAE discovered emission in very high gamma rays of this object in 2007. This work represents the first evidence for gamma ray emission in a black hole binary system.*

The MAGIC group at IFAE is currently under the direction of J. Cortina. The group has significant political and organizational responsibilities in the collaboration: A. Moralejo is the Software Coordinator and a member of the Executive Board. M. Martínez is the Deputy Chairman of the Collaboration Board. J. Cortina is the convener of the Physics Working Group on Galactic Sources.

The collaboration published eleven journal papers in 2007, many of which were initiated or had a strong participation of IFAE physicists:

- J. Rico was singly responsible for the analysis which produced the discovery of Cygnus X-1, the first stellar mass black hole ever observed in gamma rays (see figure for an artist's view of this binary system). The source was not found to emit on a regular basis, but evidence of gamma-ray signals was obtained during a search for faster-varying signals. A short flare lasting less than 24 hours was registered in September 24th, 2006, during a period of enhanced X-ray activity.
- E. de Oña-Wilhelmi was involved in the observation of the supernova remnant Cassiopeia A, one of the most probable hadronic accelerators in our galaxy and as such one of the sources of the cosmic rays. J. Cortina also collaborated in the discovery of gamma ray emission from the direction of the supernova remnant IC 433. The source has been named MAGIC J0616+225 because its nature remains uncertain as of now. It may be associated to a region of interaction of cosmic rays and a nearby molecular cloud.
- D. Mazin was the main actor in the discovery of gamma ray emission from the active galactic nucleus (AGN) 1ES 1011+496, at a distance  $z=0.212$  and hence a useful probe of the density of intergalactic light density. The PhD thesis of E. Domingo-Santamaría at the institute gave also rise to the first upper limits to the very high energy gamma ray emission of a starburst galaxy, Arp 220, and the PhD thesis of M. Gaug to the first upper bounds above 85 GeV to the prompt emission of

Gamma Ray Bursts (GRB), which were extracted for nine GRBs in 2005 and 2006.

- M. Errando and M. Martínez have been involved in the interpretation of the energy-dependent time delay observed in the active galactic nucleus Markarian 501. MAGIC observations of this AGN caught two episodes of fast and intense flux variability ("flares"), with doubling times as low as 2 minutes, the fastest ever observed in AGNs. There is also a shift of arrival time with energy (see the energy-dependent light curves, in 4-minute time bins), with the more energetic photons arriving later. This effect may be interpreted as a stringent limit on the acceleration models, and potentially even as a limit on the mass scale of quantum gravity (if synchronous production is assumed), for which some models predict such shifts in time.
- The Flash-ADCs of the MAGIC telescope were upgraded to a faster (2 GSps) digitization speed version in 2007. D. Tescaro and A. Moralejo were able to use this faster sampling to extract additional Physics information from the Cherenkov shower images which significantly improves the sensitivity of the telescope.

The PhD thesis of E. Aliu on the study of pulsar-wind nebulae with MAGIC and the master thesis of D. Tescaro on the sensitivity improvement of the telescope with the new FADCs were completed in 2007. It is also worth to mention that MAGIC set up a prize for young scientists in 2007 and the two prizes which were awarded in this year both went to members of the IFAE group: one to D. Tescaro and the second one to J. Rico for the aforementioned results.

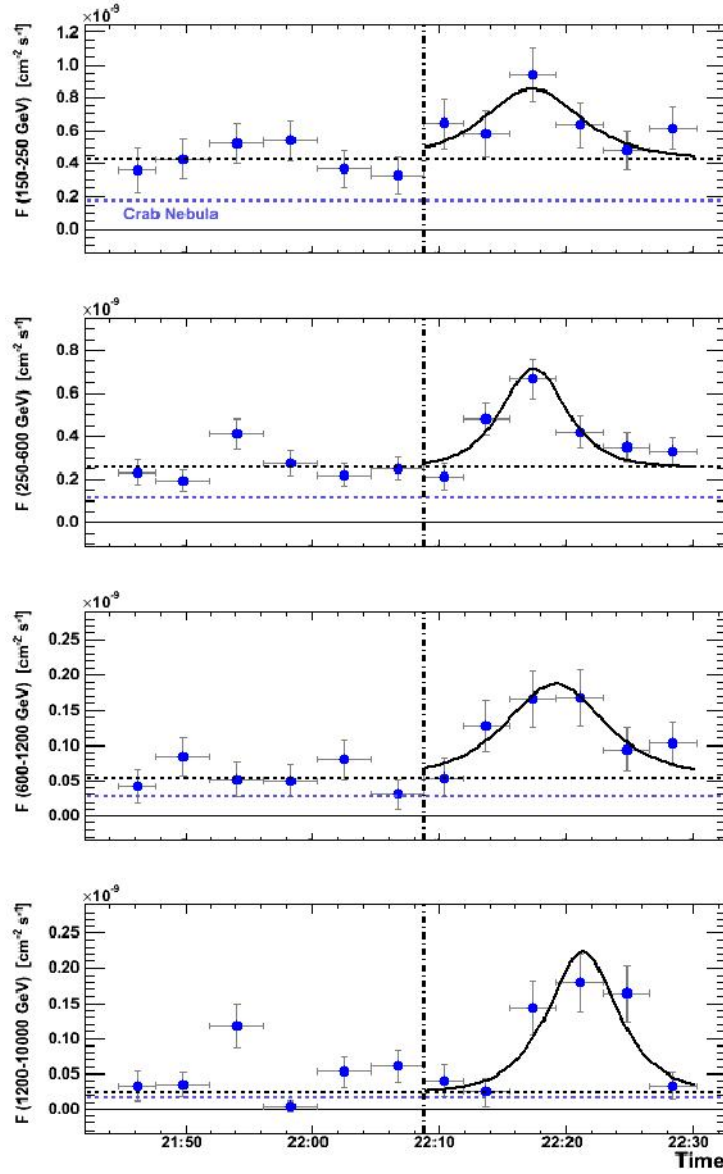

A short-lasting episode (flare) of gamma ray emission in the AGN Markarian 501. The flare is the shortest ever observed in gamma rays. The figure shows the gamma ray flux as a function of time for four different energy bands, ranging from 150-250 GeV at the top panel to  $>1200$  GeV at the bottom. The flare arrives later with growing energy.

Work started in 2005 to construct a second MAGIC telescope (MAGIC-II) which, in coincident operation with the original MAGIC-I, improves the spectral and angular resolutions, and noise rejection. It should deliver a factor of two improvement in sensitivity and a lower energy threshold. Most of the systems of the telescope finished the design and prototyping phase and started production in 2007

with the aim of the final installation before the inauguration in September 2008 (see figure for the status of the telescope at the end of 2007). MAGIC-II, in principle, should as closely as possible resemble MAGIC-I, but new technologies and experience with MAGIC-I suggested changes in several areas, all aiming at the best possible performance for low-energy showers with their

modest photon yield: advanced photosensors with higher sensitivity, increased camera area instrumented homogeneously with small-size pixels,

mirror elements with larger surfaces, improved non-interfering mirror adjustment, digital signal readout with improved time resolution.

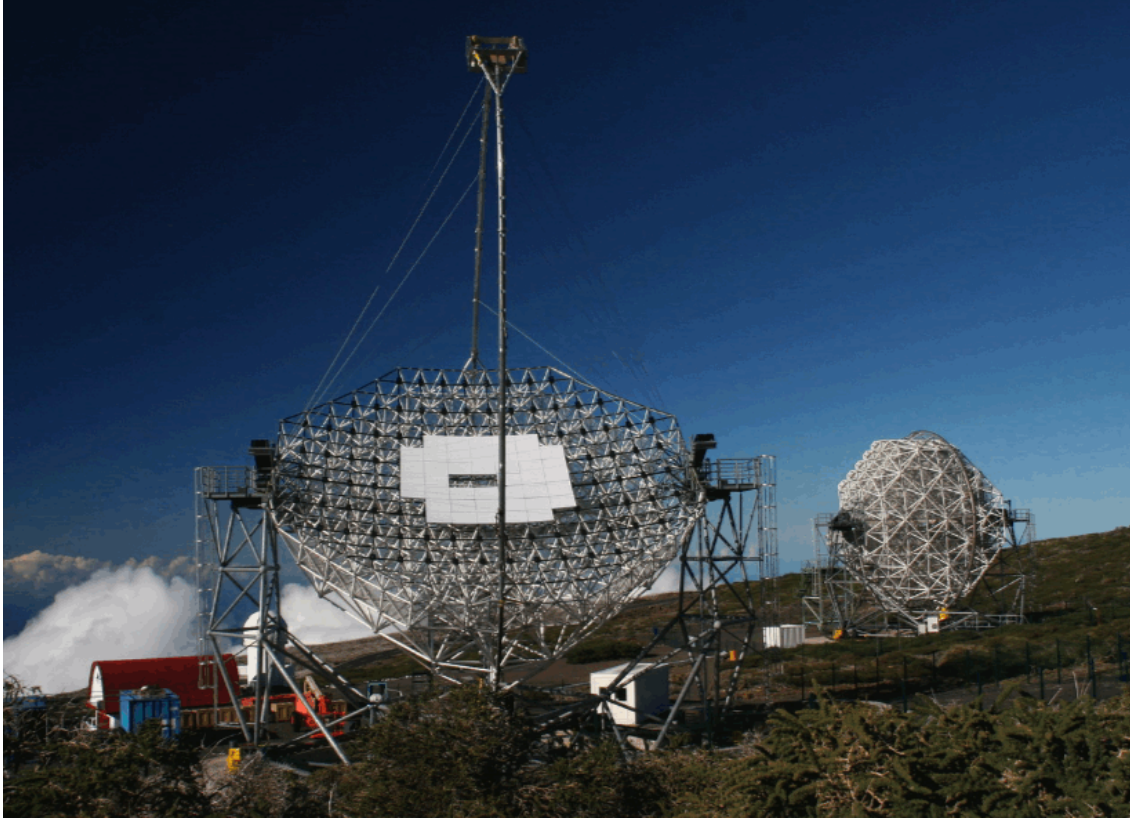

*A picture of MAGIC-II after mounting 20% of its mirrors in summer 2007. In the background, the electronics control building and the first MAGIC telescope.*

- The IFAE group is responsible for the reception of the analogue optical signals produced by the camera of MAGIC-II, the signal conditioning and level-0 trigger (trigger discriminators). The optical reception of the signals of the 1039 channels of the camera takes place in a system of 60 VME boards. Each of them is a 10-layer controlled-impedance PCB hosting 24 channels.
- IFAE has also developed and built the readout and data acquisition of MAGIC-II in cooperation with the INFN Pisa group. The readout of the telescope uses the so-called DOMINO chip with a 2-4 GHz sampling rate. The last prototypes of both hardware systems were ready at the end of 2007/beginning 2008. Responsible for these technical developments are the electronic engineers M. Barceló and J.M Illa.
- R. Zanin is responsible for the extension of the central control software of the two-telescope system.
- J. Rico and R. Firpo took care of the setup of the data center of the two telescopes. The data center is a collaboration of the Spanish groups from IFAE, UCM and UAB, and is hosted at the nearby Port d'Informació Científica (PIC).

## 7.5 The CTA (Cerenkov Telescope Array) Project (Manel Martinez)

In the field of very-high-energy gamma ray astronomy, Europe, with the H.E.S.S. and MAGIC instruments, holds a clear leading position. The spectacular astrophysics results from current Cherenkov instruments have generated considerable interest in both the astrophysics and particle physics communities and have spawned the urgent wish for a next-generation, more sensitive and more flexible facility, able to serve a large community of users.

The answer of the whole European VHE gamma ray community together to this wish is the “Cherenkov Telescope Array” (CTA). CTA will be an advanced facility for ground based very-high-energy gamma ray astronomy, based on the observation of Cherenkov radiation. It builds on the mastery of the Imaging Atmospheric Cherenkov Telescope technique acquired by the H.E.S.S. and MAGIC installations. From the successes of H.E.S.S. it exploits the concept of telescope arrays and stereoscopic analysis for improving the current

sensitivity by one order of magnitude. From the success of MAGIC it exploits the use of large telescopes to attain the lowest possible threshold. Both approaches have proven to be extremely successful for gamma rays of energies above few tens of GeV and have opened a new window in astronomy: the detailed study of the universe at the largest energies to study the most extreme astrophysical phenomena and fundamental physics.

The 3 main wishes of the European VHE gamma ray community to be fulfilled by CTA are:

- 1) A wide energy coverage: four decades, from 10 GeV to 100 TeV
- 2) A sensitivity at least one order of magnitude better than any existing installation: better than 1 milliCrab at the intermediate energies.
- 3) Two observatories for all-sky monitoring capability: a northern observatory with emphasis on extragalactic studies and a southern one mainly for galactic studies.

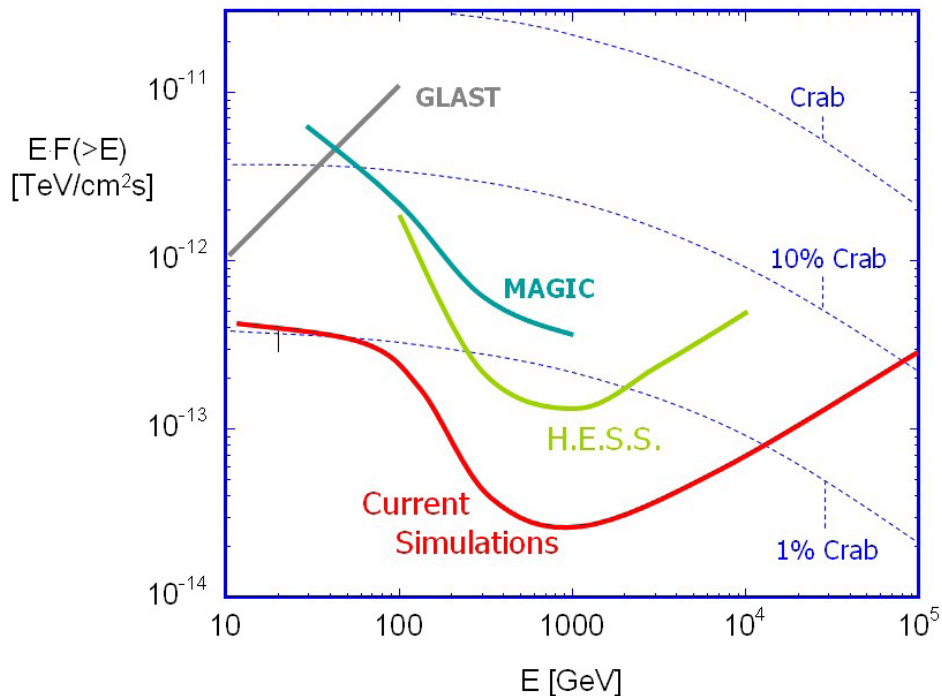

*Expected sensitivity of CTA compared with the sensitivity of the best current installations.*

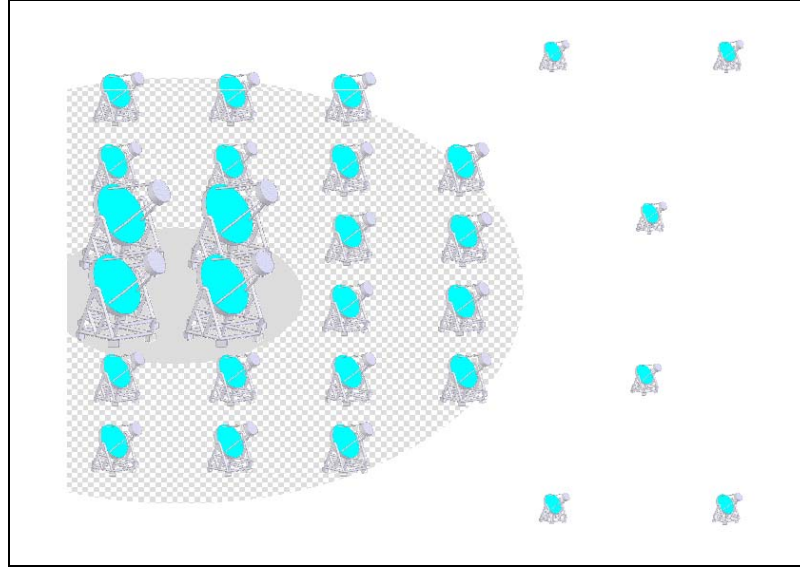

*Possible conceptual layout for the CTA observatory (not to scale)*

The facility has a price tag of 150 MEuros (50 MEuros for the northern observatory and 100 for the southern one) and will consist of an array of several tens of Cherenkov Telescopes probably of two or three different sizes: few large telescopes in a compact configuration for the lowest threshold, a few tens of mid-size telescopes for the high-sensitivity intermediate-energy region, several tens of small telescopes spread over a large area for the highest energies.

The proposed CTA facility shall build on the mature technology developed and proven by H.E.S.S. and MAGIC but deployed on an unprecedented scale: about one hundred telescopes altogether.

The CTA project for the first time unifies the research groups working in this field in Europe in a common strategy, resulting in a unique convergence of efforts, human resources, and know-how. Interest in and support of the project is shared by over 300 scientists in all over Europe, in the Czech Republic, Finland, France, Germany, Italy, Ireland, the Netherlands, Poland, Spain, Switzerland, and the United Kingdom, wishing to use such a facility for their research and willing to contribute to its design and construction. The concept of CTA emerged by the end of 2005. CTA was included in the ESFRI (European Scientific Forum for Research

Infrastructures) roadmap from 2006 as an “Emerging Project” and during 2006-2007 several working groups starting developing different aspects of the concept for a Letter-of-intent. During that phase the MAGIC-IFAE group participated actively in some of the working groups and M. Martinez (IFAE) was convener of the “Camera and Electronics” working group.

By mid 2007 the CTA collaboration submitted an application to the FP7 program of the European Union for a Design Study and 10 Work Packages (plus two administrative ones) were defined. Two of these Work Packages have since then coordinators from Spanish Institutions: the Physics WP is coordinated by D. Torres (ICE-IEEC) and the Atmospheric Monitoring and Calibration WP coordinated by M. Martinez (IFAE). Although the FP7 application was recently turned down, the CTA activity continued with the structure set up for the FP7 application. Meanwhile the CTA project got very clear support from ASPERA-ApPEC (Astroparticle Physics ERA-net) and from ASTRONET (Astronomy and Astrophysics ERA-net), having been placed with high priority in their respective roadmaps. A request to the ESFRI committee to include CTA with high priority in their 2008 roadmap was also submitted by the end of 2007.



## 7.6 The DES (Dark Energy Survey) Project (Ramon Miquel)

Since 2005, a group at IFAE, alongside a group at ICE (Institut de Ciències de l'Espai) and another at CIEMAT (Centro de Investigaciones Energéticas, Medioambientales y Tecnológicas) in Madrid, collaborates in the Dark Energy Survey (DES) international project, led by Fermilab (USA). The main goal of the project is to survey 5000 square degrees of the southern galactic sky, measuring positions on the sky, shapes and redshifts of about 300 million galaxies and 15000 galaxy clusters. Furthermore, another 10 sq. deg. of the sky will be repeatedly monitored with the goal of measuring magnitudes and redshifts of over 1000 distant type-

Ia SNe. These measurements will allow detailed studies of the properties of the so-called “dark energy” that drives the current accelerated expansion of the universe.

To perform the survey, the DES Collaboration is building a large wide-field CCD camera (DECam) that will give images covering 3 sq. deg. on the sky. The camera, shown in the figure, will be mounted at the prime focus of the 4-meter Blanco Telescope, located in Cerro Tololo in Chile. In return, DES is granted 30% of all the observation time for 5 years (2011-2015).

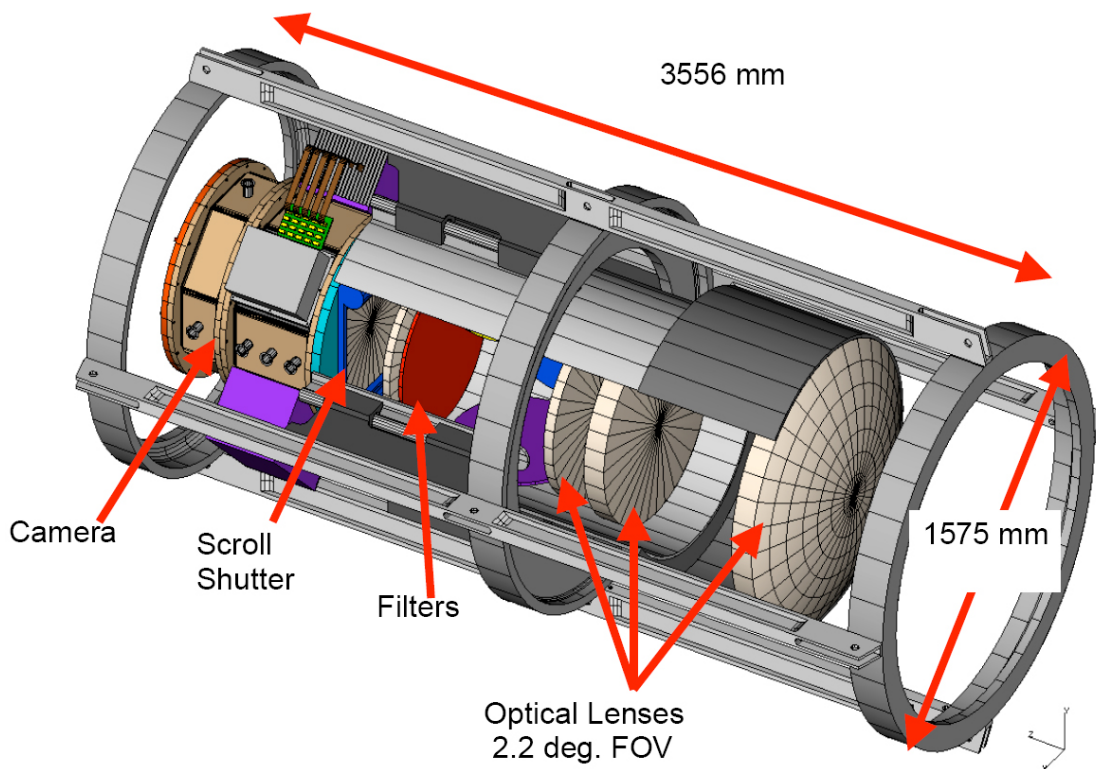

*A view of DECam, the camera being built by DES.*

The three Spanish groups, funded by the Program of Astronomy and Astrophysics, which is part of the National Plan of I+D+I, will build the whole set of read-out electronics boards of DECam, and are designing three out of the four main boards: the Clock and Bias Board (CBB) at CIEMAT, and the Master Control Board (MCB) and the Transition Board (TB) at IFAE.

During 2007 the board design at IFAE proceeded at the expected pace:

- Two versions, V1, and V1.1, of the TB were designed, laid-out, produced and tested. After fixing some bugs in V1, two V1.1 cards are working now, one at Fermilab and the other at CIEMAT. One of the cards can be seen in the figure.
- An initial design of the schematics and firmware for the MCB was produced.

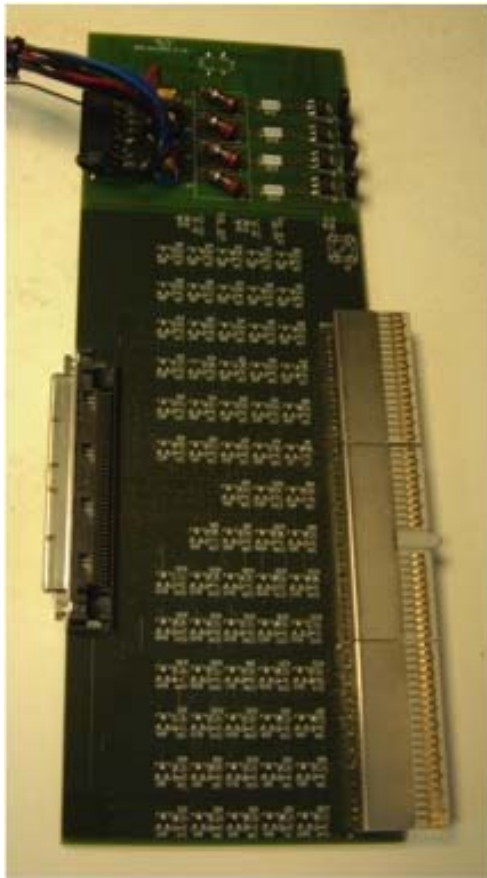

*A view of one of the transition boards produced at IFAE.*

- Following tests performed at Fermilab, modifications were done to the Slink software. Slink sends the data between the MCB and the data acquisition computer. IFAE proposed using the open Slink standard, used at CERN, instead of the proprietary Systran link.

In parallel to the electronics board design, the CCD and electronics test set-up (shown in the figure, and described in detail in last year's report) was moved from ICE to IFAE, and was fully automated and characterized. The automation included:

- Using LabView to control the optical bench and all the instruments therein from a single PC.
- Control of the temperature in the cube to less than 0.5 K.
- Writing of protocols for the safe start-up/shut-down of the optical bench.
- Production of a computer controlled moving holder for the test CCD.
- Optical beam optimization.
- Selection of the optical filters.

With this fully automated set-up, it was possible to fully characterize the optical system, producing light intensity maps like those shown in the figure, every 5 nm in wavelength, from 300 to 1200 nm.



A photograph of the test bench for the DES electronics. To the left of the picture one can see the cube that contains the CCD, together with a small liquid nitrogen Dewar, to maintain it cold. On the right there is an optical system to illuminate the CCDs. The electronics are inserted in a crate in the back of the picture (not seen).

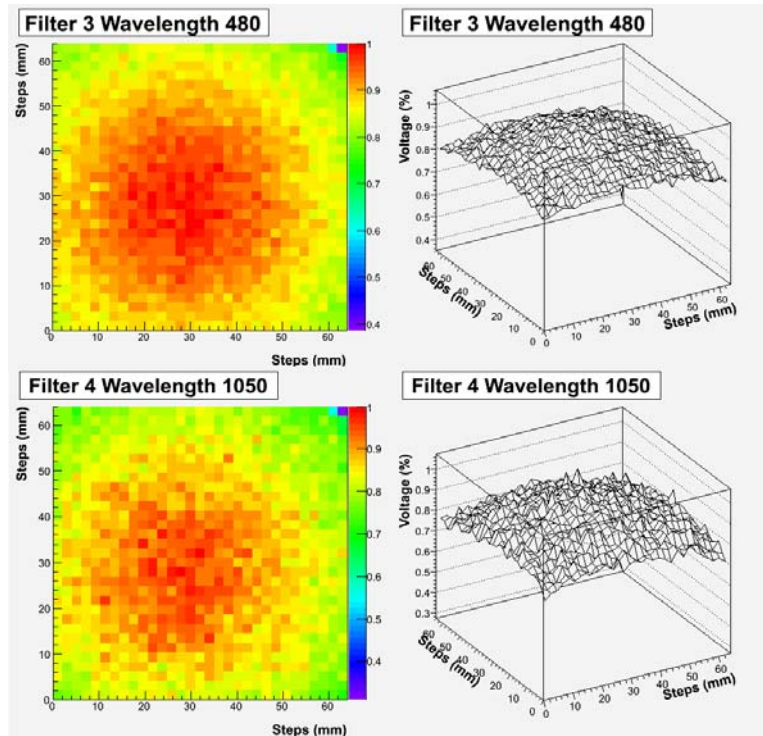

Transmission maps for the whole CCD test set-up, for two different wavelengths, 480 nm (top), 1050 nm (bottom). Maps like these were obtained for wavelengths between 300 nm and 1200 nm at 5 nm intervals.

Once the test set-up is characterized, it can be used to study properties of DES CCDs. Out of the CCDs delivered to DES, only about 25% meet the stringent requirements set by the collaboration on issues like charge transfer efficiency, noise, diffusion, etc. The system allows us to participate in the selection process of the DES CCDs, which is coordinated by Fermilab. For the moment, the system has been exercised by testing smaller CCDs that are by-

products of the DES production runs. The tests include exposing the CCDs to both visible light and X-rays from an Americium 241 source. The Americium source permits an absolute measurement of the charge-transfer efficiency of the CCDs, by looking at the height of the known peaks in the measured Americium spectrum. One such spectrum is shown in the figure.

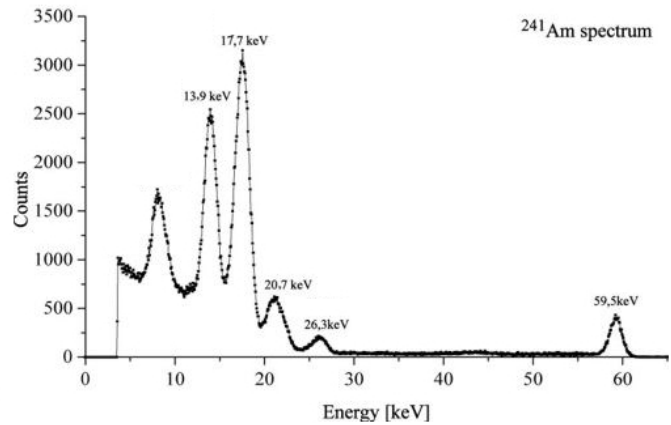
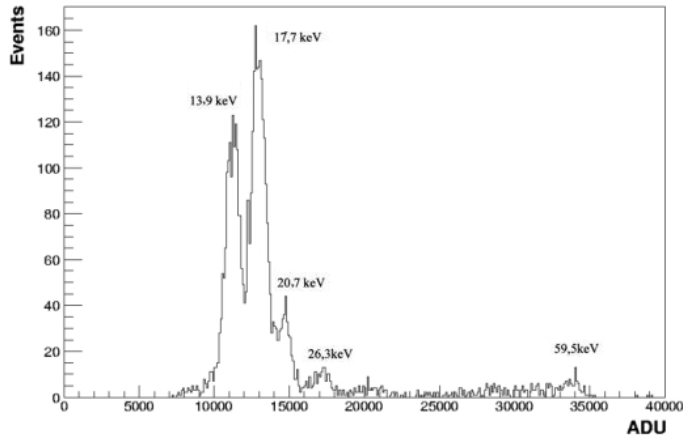

Left: Americium 241 spectrum showing the characteristic peaks measured with a test CCD in the test set-up at IFAE. Right: Expected spectrum. The leftmost peak lies inside the pedestal region of the set-up, and, hence, could not be measured.

Another important area of activity was the preparation of the analysis of the DES data. Here the work of the IFAE group concentrated on the use of type-Ia supernovae (SNe) in cosmology. In preparation for the analysis of DES supernova data, some members of IFAE, ICE and CIEMAT joined in 2007 the program of spectroscopic follow-up of the SNe found in the Sloan Digital Sky Survey (SDSS-II) project, in a redshift range between 0.1 and 0.4. The IFAE group led a proposal to the Italian “Telescopio Nazionale Galileo” (TNG) in La Palma that was awarded four full nights of observations in Fall 2007. The observations were carried out by members of IFAE, ICE and CIEMAT, and resulted in spectra of about 25 objects, out of which nine turned out to be type-Ia SNe, including an extremely peculiar one, SN2007qd, and four were type-II SNe. The figure shows the measured spectrum of a normal

type-Ia supernova, SN2007ph. The observations were reported in three CBET circulars:

- Bassett, B. et al., “Supernovae 2007ju and 2007kl-2007ld”, Central Bureau Electronic Telegrams, vol. 1098 (2007).
- Bassett, B. et al., “Supernovae 2007oq-2007pj”, Central Bureau Electronic Telegrams, vol. 1128 (2007).
- Goobar, A. et al., “Supernova 2007qd”, Central Bureau Electronic Telegrams, vol. 1137 (2007).

During 2008 the flux-calibrated spectra of these supernovae will be carefully extracted from the raw data.

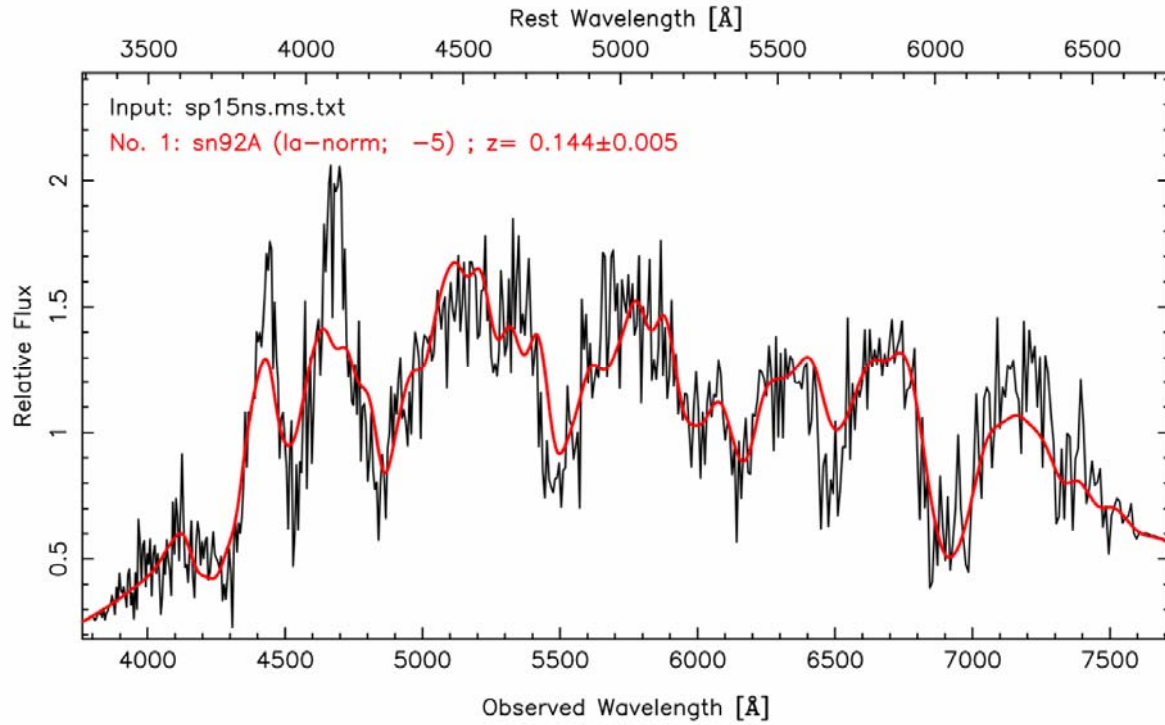

*Spectrum of supernova SN2007ph, at redshift  $z=0.144$ , taken on November 4<sup>th</sup> 2007 at TNG. The lower scale shows wavelengths in the observer frame, while the top scale shows the same wavelengths in the supernova frame. The characteristic broad Si-II feature at about 6000 Angstrom in the supernova frame is clearly visible. Superimposed is a template of a standard type-Ia supernova redshifted to  $z=0.144$ , observed 5 days before maximum light. The match between the two spectra is excellent.*



## 7.7 The PAU (Physics of the Accelerating Universe) Project (Enrique Fernández)

---

The PAU (Physics of the Accelerating Universe) project was started in the context of the Consolider Ingenio 2010 Program of the Spanish Ministry of Education and Science (now Ministry of Science and Technology). The Consolider is a special program in that it finances groups for five years in projects with the potential of being highly competitive internationally. Or, to use the words stated in the announcement of the Program, "projects that can produce a qualitative jump in the research of the participating groups". Some of us at the IFAE, involved in observational cosmology (see DES project, elsewhere in this report) thought of the possibility of submitting a proposal in this field, in which we could assume a leadership role, intellectually and materially. Such a major project, conceived and led from Spain from the start, could indeed represent a qualitative jump in our research, since that action would not have a precedent in this particular area of science.

Together with colleagues from other six Spanish Institutions, namely, CIEMAT (Madrid), IAA (Granada), ICE-IEEC (Barcelona), IFT-UAM (Madrid), IFIC-UV (Valencia) and PIC (Barcelona), a proposal for a generic project was submitted in January of 2007. Out of 71 competing proposals, this was one of 42 selected for a second phase of the Program, in the spring of that year. Subsequently a new, more detailed proposal was submitted, and this was one of the 27 finally approved in June 2007, with a starting date in October 2007. This proposal focuses in the study of dark energy, although the scientific reach of the experiment extends beyond this topic. The PAU team includes experimental and theoretical particle physicists, cosmologists and astronomers. The Coordinator for the project is from IFAE (E. F.), and therefore IFAE is the Coordinating Institution. The members of IFAE in PAU are: Laia Cardiel, Enrique Fernández, Josep Antoni Grifols, Eduard Massó and Ramon Miquel.

There are several distinct goals within PAU. One of them is to study dark energy from the theoretical physics point of view. As explained below the nature

of dark energy is far from being understood. We believe that bringing together astronomers and particle physicists, theorists and experimentalist is the best approach to study this problem from a theoretical perspective. Another goal is to carry out educational and outreach activities, both within the team, given the different backgrounds of those involved, and towards society in general. Yet another goal, and the most substantial one in terms of resources, is to construct an instrument consisting of a very wide-field CCD camera ( $\sim 6 \text{ deg}^2$ ) for galaxy photometric red-shift measurements based on a large number of narrow-band filters, and to prepare a large galaxy survey, of about  $8000 \text{ deg}^2$  and up to  $z=0.9$  in red-shift, with such an instrument installed in a 2 meter class telescope. The telescope would be an existing telescope, suitably modified, or, preferably, an entirely new telescope, fully dedicated to the survey in an initial phase.

Since this is the first time that this project is presented in the IFAE Report of Activities we briefly explain below the context of dark energy, before we address its main goals.

### The Standard Cosmological Model

Over the past decade the combined analysis of observations of the Large Scale Structure of the universe, of measurements of Cosmic Microwave Background temperature anisotropies and of distance-scale measurements provided by the observation of type Ia Supernova, have led to a remarkably consistent cosmological model, known as the Standard Cosmological Model (SM), or  $\Lambda$ CDM (Lambda Cold Dark Matter Model). The SM consists of a universe described by Einstein's theory of general relativity with flat geometry, containing the known baryonic matter, radiation and light neutrinos, an unknown form of collisionless (weakly interacting) matter known as "cold dark matter", and dark energy. The observations show that the matter part consists of about 20% in the form of ordinary (baryonic) matter and that the other 80% is cold dark matter, with a very small contribution given by

neutrinos and radiation. Today this matter part accounts only for about 25% of the critical density, the other 75% being "dark energy". The dark energy exerts negative pressure and its fraction of the critical energy is variable with time, having become dominant only recently (at red-shift below 1). On the largest scales the universe is nearly homogeneous, but contains a spectrum of density fluctuations that in the SM are assumed to be adiabatic (i.e. only the total density varies, but not the proportion of the different components) and Gaussian. With this set of assumptions, the gravitationally-driven growth of the density fluctuations accounts for the formation of galaxies and large-scale structure (clusters and super-clusters), as far as the present observations have been able to tell. The simplest consistent theory for the origin of the primordial perturbations is that they are quantum fluctuations generated when the universe underwent an early phase of "inflation", an episode that could be explained if a component similar to dark energy was present at early times, with much higher density than the dark energy we observe today.

### Dark Energy in perspective

In the framework of General Relativity the accelerated expansion can be "explained" by any quantity  $\Lambda$  that would make positive the right hand side of the following equation, one of Friedman-Lemaître's:

$$\frac{\ddot{a}}{a} = -\frac{4\pi G}{3}(\rho + 3p) + \frac{\Lambda}{3} \quad (1)$$

In this equation, with the standard FRW metric,  $a(t)$  is the scale factor (equal to 1 at present,  $a(0) = 1$ ), and  $\rho$  and  $p$  are the density and pressure, respectively, of the matter-energy fluid that permeates the whole universe. The quantity  $\Lambda$  can be a cosmological constant, first introduced by Einstein to make the universe static (to compensate exactly the other term), or can be a form of energy with negative pressure as explained below. We simply do not know at all what could be the cause of the apparent accelerated expansion. To solve the above equation one would need a relation between  $\rho$  and  $p$ , or equation of state, usually parameterized in the form

$$p = w(t)\rho \quad (2)$$

For matter and radiation the equation of state is known. It is of the above form with  $w=0$  and  $w=1/3$ , respectively. For these two components of the universe one then has that  $\rho+3p > 0$ . For them the right hand side of eq. (1) (without the  $\Lambda$  term) is negative, and therefore a universe with only these components will be expanding with a decreasing rate, as it is to be expected. From eq. (1) it is also apparent that a component with negative pressure, namely with  $w < -1/3$ , will give rise to a term  $\rho+3p < 0$ , and therefore to an accelerated expansion if it dominates over the other. Such a component is usually called "dark energy". A cosmological constant  $\Lambda$  can also be cast in the form of dark energy. To see this we can introduce a component with a positive density

$$\rho = +\frac{\Lambda}{8\pi G} \quad (3)$$

and a negative pressure equal to its positive density

$$p = -\frac{\Lambda}{8\pi G} \quad (4)$$

that is, with  $w = -1$ . Including such a component into the right hand side of eq. 1, without a cosmological constant, we get a term  $\Lambda/3$ , the same as with a cosmological constant.

The measurement of  $w$  is therefore of prime importance to understand the evolution of the universe. But  $w$  alone is not sufficient. This is apparent from the other of the two Friedman-Lemaître equations (for a flat universe)

$$H^2(a) = H_0^2 \left[ \Omega_M a^{-3} + \Omega_R a^{-4} + \Omega_{DE} a^{-3(1+w)} \right] \quad (5)$$

Here we have introduced the densities of matter, radiation and dark energy in terms of the critical density  $\rho_c$

$$\Omega_i = \frac{\rho_i}{\rho_c} \quad \text{with} \quad \rho_c = \frac{3H_0^2}{8\pi G} \quad (6)$$

At present the radiation term is negligible and the flatness constraint implies that

$$\Omega_M + \Omega_{DE} = 1 \quad (7)$$

Instead of  $a(t)$  one can use the red-shift defined by

$$z = \frac{\lambda_0 - \lambda_e}{\lambda_e} \quad (8)$$

where  $\lambda_0$  and  $\lambda_e$  are the measured and emitted wavelengths of the light from a source at red-shift  $z$ .



It can be related to  $a(t)$  by  $a(t) = 1/(1+z)$ , where  $t$  is the time of the emission at the source at red-shift  $z$ . Therefore eq. (5) can be written as

$$\frac{H^2(z)}{H_0^2} = \Omega_M (1+z)^3 + (1-\Omega_M)(1+z)^{3(1+w)} \quad (9)$$

From the above equation one sees that  $H(z)$ ,  $\Omega_M$  and  $w$  are related. A measurement of any of them provides a constraint between the other two.

In the PAU Survey we propose to measure the expansion rate  $H(z)$ , thus providing a relation between  $\Omega_M$  and  $w$ .

### Baryon Acoustic Oscillations

Baryon Acoustic Oscillations (BAO), provide a way of measuring  $H(z)$ . BAO have their origin in the density fluctuations created by acoustic waves in the photon-baryon plasma before recombination, generated by primordial perturbations. After recombination the photons decouple and propagate freely. We see the effect of the primordial perturbations in the temperature fluctuations of the CMB. At recombination the acoustic waves stall. The peaks and troughs of the pressure (density) waves give rise to accumulation and rarefactions of baryonic and dark matter. As a result there should be a correlation between the densities of matter at the scale of the sound horizon distance at recombination. This scale can be determined from CMB observations and it is equal to  $r_{\text{BAO}}=146.8\pm 1.8$  Mpc (or  $r_{\text{BAO}}=105.7\pm 1.3$  h<sup>-1</sup> Mpc for  $h=0.72$ ) comoving, for a flat  $\Lambda$ CDM Universe. This distance constitutes a "Standard Ruler" and its measurement at different red-shifts gives information on the expansion history of the Universe.

The BAO scale can be determined from a galaxy survey. The angular position and red-shift of galaxies give a measurement of the clustering of mass in three dimensions. The BAO signature will show up as a peak in the two-point correlation function of the mass distribution. In such a survey one does not need in principle the absolute flux or shape of the galaxies. On the other hand there are effects that can give rise to systematic uncertainties. First, there is the issue of biasing: the light from galaxies is a biased estimator of the matter content. Second there is non-linear physics that enters in

galaxy formation, and third, there are red-shift distortions induced by peculiar velocities. But all these effects tend to predominantly change the amplitude of the correlations but not the position of the peak. From this point of view BAO, as a probe of dark energy, is less affected by systematic uncertainties than other probes, as some recent reports (from the Dark Energy Task Force in the US and from ESO in Europe) have pointed out. In any case, its systematic uncertainties are different from those of other methods.

On the other hand, since the scale is very large, its observation requires sampling of the mass distribution over very large volumes and therefore very large surveys.

The BAO scale has been detected in the Sloan Digital Sky Survey data, as an excess in the two-point correlation function of the mass distribution, with the mass traced by Luminous Red Galaxies (LRG) in a sample of about 45,000 LRGs, with spectroscopically determined red-shifts.

The distance can in principle be measured "radially", along the line of sight, and "in angle", across that line, as an angular distance. The two distances are related differently to the expansion rate  $H(z)$ . The radial distance is given by

$$dr(z) = \frac{c}{H(z)} dz \quad (10)$$

while the angular distance is proportional, for a flat universe, to an integral of  $H(z)$ ,

$$d_A(z) = \frac{c}{1+z} \int_0^z \frac{dz'}{H(z')} \quad (11)$$

The different dependence of the distance scale on  $H(z)$  translate into a different precision in the determination of the cosmological parameters depending on whether the information comes from the line of sight or from the angular distance. Roughly speaking the volume of a galaxy survey providing radial information needs to be only 10% of the volume needed if only the transverse information is available, to obtain similar precision in the cosmological parameters. Observationally

then one has two competing aspects: covering a large volume is more easily done with a photometric survey, but measuring the BAO scale in the radial direction requires to measure  $z$  with precision, such as what can be better achieved with spectroscopic observations.

## The PAU Survey

In PAU a photometric red-shift survey is proposed, but with enough precision in the determination of red-shifts as to be able to measure the BAO scale radially [See Benítez et al., arXiv:0807.0535 (astro-ph), for a detailed discussion of the PAU Survey capabilities].

The precision needed in the determination of the red-shift has been estimated from simulations. They show that a precision in  $z$  of the order of  $0.003(1+z)$  is near optimal. A smaller precision will smear the peak of the correlation function while a higher precision does not add significantly, as other effects, such red-shift space distortions and non-linearities can introduce uncertainties comparable to this value.

The high precision is possible by targeting Luminous Red Galaxies (LRGs) as tracers of mass. These galaxies have a characteristic break in their spectrum at approximately  $4000\text{\AA}$  rest frame. The proposed PAU camera will have 42 filters, covering between  $4000\text{\AA}$  and  $8000\text{\AA}$ , supplemented by two wide filters similar to the SDSS  $u$  and  $z$  bands. Simulations show that this would allow the determination of the position of this break with the required  $0.003(1+z)$  precision. In the next figure is shown the layout of filters, superposed to an LRG spectrum.

The proposed survey will be carried out with a telescope/camera combination with an *étendue* of about  $20 \text{ m}^2\text{deg}^2$ , equivalent to a 2 m telescope equipped with a  $6 \text{ deg}^2$ -field of view camera, and covering  $8000 \text{ deg}^2$  in the sky in four years. With this survey it is expected to measure positions and red-shifts of over 14 million LRGs up to 22.5 absolute magnitude in the red-shift interval  $0.1 < z < 0.9$ . This population has a number density  $n > 10^{-3} (\text{Mpc/h})^{-3}$  galaxies within the  $9 (\text{Gpc/h})^3$  volume to be sampled, ensuring that the error in the

determination of the BAO scale is not limited by shot-noise.

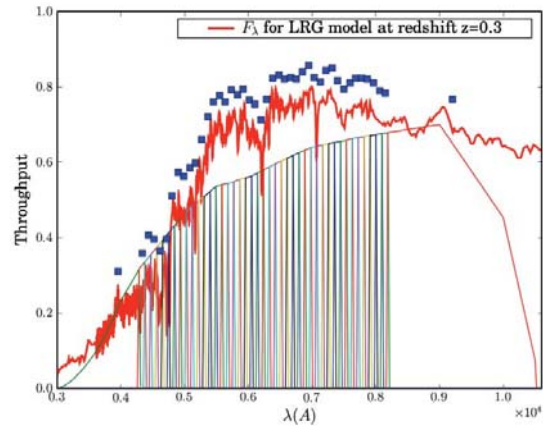

*Scheme of the filters of the PAU Camera, with a superimposed spectrum of a LRG at  $z=0.2$  (red). Here the "4000Å" break is approximately at  $4800\text{\AA}$ , which gives the red-shift. In blue are the fluxes that will be observed through the filters. Other features of the spectrum different from the  $4000\text{\AA}$  break could also be incorporated into the determination of the red-shift (from Benítez et al., see text).*

The design and construction of the PAU camera is one of the main deliverables of the PAU Consolider project. A forerunner of the camera, with 20 filters, is that of the Alhambra project, led by members of the PAU team in the German-Spanish Calar Alto Observatory in Almería.

For the telescope the baseline option is a dedicated telescope presently being planned for the Sierra de Javalambre in Teruel, with support from the Government of Aragón. A 2.3 m diameter telescope with a  $6 \text{ deg}^2$  FoV gives the  $20 \text{ m}^2\text{deg}^2$  etendue. With a pixel size of  $0.4''$  and state of the art CCDs it is possible to reach a signal/noise of about 5 for a star of absolute magnitude of 23.5 in about 300 sec, which implies that the survey can be carried out in about five years. The image scale will be such that a  $15\mu\text{m}$  pixel translated into  $26 \text{ arcsec/mm}$ , which is sufficient for the image requirements of the survey.

Here we have only considered BAO, but the PAU data will also contain information on other probes of dark energy. With the above precision in  $z$  one could attempt to measure the power spectrum of density fluctuations. The accurate red-shifts could be combined with measurements of other projects,

where other parameters related to dark energy, such as weak lensing effects, can be better measured.

The survey will also give high-quality red-shifts for millions of galaxies. For instance, these PAU quasi-spectra will allow the study of many parameters related to galaxy evolution such as stellar masses and age distributions, metallicity, dust absorption and others. The PAU data will also allow an improved separation of stars and quasars compared to other survey. In summary, the PAU survey will contain a wealth of astronomical observations.



## 7.8 The X-Ray Projects

(Mokhtar Chmeissani)

---

### 3D Breast Biopsy System

The IFAE activities in the field of digital X-ray imaging go back more than a decade. It took a significant leap with the development of the FP5 programme project “Detection of Early Markers in Mammography”, also known as Dear-Mama. The Dear-Mama project (2002 – 2006) was led by IFAE and produced two radiography machines, one for mammography and one for bone radiology, and one patent that has been accepted in the USA and China, and is still pending in the EU. It is important to emphasize that the bone radiology was based on CdTe pixel sensors with a pixel pitch of 55µm, which characteristics make it a unique radiography machine in terms of high spatial resolution and very low radiation dose. However, as of 2005, the activities of the IFAE X-ray group in the Dear-Mama project were winding down because the hardware components had been delivered while new ideas and projects had started to evolve, in correlation with the know-how that had been developed and accumulated during the execution of Dear-Mama project.

IFAE in collaboration with three more institutions, Centro Nacional Microelectronics (IMB), UDIAT Centre Diagnostic, and EMSOR S.A. has developed a 3D real-time breast biopsy machine (patent pending). To realize the project we have acquired a second hand LoRad biopsy machine which has been converted to a state-of-art biopsy machine. It has been fitted with a provisional CdTe sensor detector of 5cm x 5cm with spatial resolution of 100µm. Preliminary results show that a clear image can be obtained with significant dose reduction when compared to the current biopsy machines in the market. Moreover, the medic can see the position of the needle inside the breast in real time and as well can see the exact position of the needle’s tip with respect to the target tissue (potential cancerous tissues), with utmost clarity in 3D. The biopsy machine is equipped with a special polarized monitor that provides a 3D vision when using polarized eyeglasses. The Biopsy machine is also

equipped with an additional monitor with dual use. In one modality it will allow the doctor to set the parameters of the X-ray exposures, such as the value of the high voltage for the X-ray tube, the time of the exposure, the current flowing in the X-ray tube, the display, and other features, and in another modality it will allow the doctor to access the archive of the patient to display the corresponding mammograms as cross-reference with lesions seen by the biopsy machine and displayed on the 3D monitor

Both the patient and the doctor will benefit from such a biopsy machine when it will be commercially available, because it will significantly reduce the time of the operation (and the trauma for the patient), from 30-40 minutes to about 5-10 minutes, and make the intervention successful from the first attempt, by eliminating uncertainties on whether the tip of the needle is on, behind, or in front of the target tissue. At the same time the doctor can see in real time if the biopsy needle is pushing away the target tissue instead of penetrating it. In summary, the 3D biopsy machine has been designed and tailored to meet the wishes of the doctors at UDIAT centre diagnostic and hence we believe that many doctors performing a breast biopsy intervention will wish to have a machine like this.

The IFAE responsibilities in this project are the design, production and assembly for both the mechanical parts as well as for the electronics. Moreover, IFAE leads in coordinating all the activities of the project.

Future plan is to improve the overall mechanics of the biopsy machine in order to give more comfort to the patient and also to allow the doctors to have easy access to different region of the breast which is not possible with the current biopsy machine table, holding the patient in a prone position.

The status of the 3D biopsy system is rather advanced. We have succeeded in having all the parts ready by end of 2007 and we expect full assembly and commissioning in the first quarter of 2008 in

order to present the machine in the 36<sup>th</sup> International Salon of Inventions, Geneva, Switzerland.

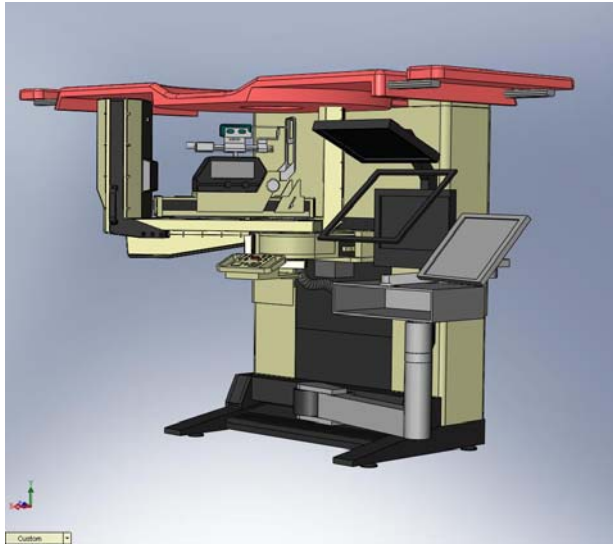

*CAD presentation of the 3D breast biopsy machine which will be commissioned in early 2008*

To accommodate all the medical devices being developed under the leadership of IFAE, a dedicated leaded-room, for X-ray activities, that matches hospital standards has been built in order to provide IFAE and collaborating research teams an ideal infrastructure for R&D in X-ray digital imaging. The two Dear-Mama machines were moved from Hospital Parc Tauli and were installed in the new X-ray room in IFAE. Beside these 2 machines, the 3D breast biopsy machine was also installed in the X-ray room in order to be commissioned in early 2008.

### **Bump-bonding Pixel Sensors**

In Dear-Mama project we have experienced serious problems in achieving high yield, good quality sensor detectors due to the low quality of the bump-bonding process. We tried many suppliers but none has provided us with a satisfactory solution. These facts have motivated us to start a new R&D to overcome this limitation. IFAE and CNM applied for coordinated project, lead by IFAE, to develop the bump-bonding process for various applications. CNM will develop the growth of the solder bumps on the pixel electrodes of ASIC/detector, and IFAE will do the flip-chip process. To achieve this goal, IFAE has formed collaboration with X-Ray Imatek

S.L. (an IFAE spin-off) to use its flip-chip machine, Suss Microtec FC150, for the duration of the R&D. This flip-chip machine is considered one of the best available for R&D on bump-bonding processes and also for production-line work. The machine is equipped with an automatic alignment system that will reduce the human error and increase productivity. Its alignment error can reach  $1\mu\text{m}$  at  $3\sigma$ . The machine was delivered by summer 2007 and is expected to be installed in the CNM clean room in early 2008. It is important to emphasise that the FC150 machine is the only machine of its type and performance in Spain.

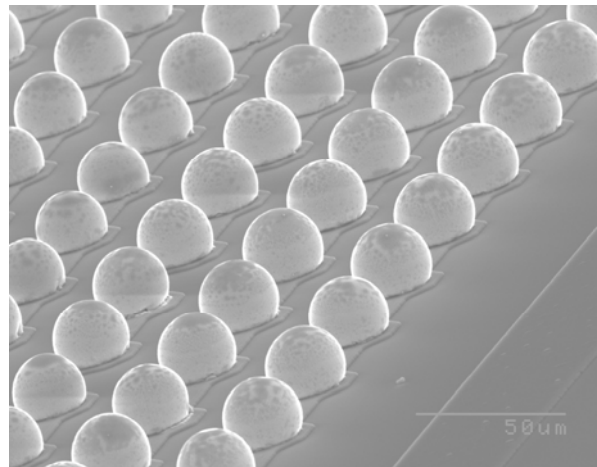

*An array of solder bumps with  $50\mu\text{m}$  pitch developed by CNM to be used with the FC150 machine.*

This R&D project will open the doors for research in the field of pixel sensors at the level of development level of pixel-array ASICs, or of the pixel-array detectors, or both. With such a high density of interconnections, it will also open more possibilities of different packaging schemes as Multi-Chips-Module (MCM) approach, which is widely used with in many applications. Certainly the Spanish particle physics community working on pixel detectors will also be a prime beneficiary of this R&D. This project is set to develop a reliable bump-bonding process for various room temperature solid state detectors, using different alloys of solder bump-balls with pixel pitches as small as  $50\mu\text{m}$ .



*Shown a photo of the flip-chip machine FC150 during test and calibration at Suss Microtec site in St. Jeoire, France.*



*Shown above, the logo of X-ray Imatek SL*

Currently X-ray Imatek S.L is based at IFAE. It also receives supports from Trampoline, the Transfer Technology Office of Universitat Autònoma de Barcelona. The profile of X-ray Imatek SL, and the scope of its business have been highly evaluated by both CDTI and CIDEM. For more details about the spin-off and its profile, one can refer to [www.xray-imatek.com](http://www.xray-imatek.com).

### **Spin-off**

In 2006, X-ray Imatek S.L (XRI), a spin-off from IFAE, was created with the help and the encouragement of the DURSI. The goal of XRI is to transform the results of the Dear-Mama project into an industrial product. The spin-off started with the smallest capital required in order to be registered in the Chamber of Commerce in Barcelona. In 2007, X-ray Imatek underwent capital expansion by letting the individuals who worked for Dear-Mama project to buy shares. At the same time X-ray Imatek submitted an application to Neotec for support. In parallel IFAE agreed to transfer the know-how of the Dear-Mama project and to license the corresponding patent to X-ray Imatek. Under this agreement, IFAE is assisting the spin-off in developing a new version of the Dear-Mama sensor detector for 3 industrial prototypes. The aim of this exercise is to make the sensor design more robust, easy to produce, easy to assemble, to be easily integrated in a dedicated mammography machine, and to meet CE regulation so that the 3 industrial prototypes can be fully evaluated in 3 different hospitals with clinical trials. The work has proceeded in the development of new readout system, new motherboard to host the sensors, new Graphic User Interface, and new mechanics to hold the sensor detector.





## 7.9 Quantum Information Theory

(Emili Bagan)

---

Quantum Information is a multidisciplinary research area where quantum physics meets fields as diverse as mathematical statistics, cryptography, computer science, and nano-technology, among others. Quantum Information employs the laws of quantum mechanics, i.e. the laws of the microscopic world for the efficient processing of certain computational tasks that are intractable within classical physics and modern computers. There is a plethora of new possibilities beyond the classical world and many puzzling and counterintuitive effects. Quantum Information Theory is the theoretical body that extends classical information theory into this new framework. The grounds for the spectacular development of Quantum Information Technology can be found in the seminal theoretical works concerning entanglement by A. Peres, the quantum cryptographic proposals of C. Bennett, G. Brassard and A. Ekert, the discovery of the quantum factorizing algorithm by P. Shor, and the quantum computer proposal by I. Cirac and P. Zoller. On the other hand, the impressive experimental advances in the fields of Atomic Physics and Quantum Optics have reached an unprecedented control in the preparation and manipulation of quantum systems. These recent advances are offering an extraordinary scenario for testing many predictions of quantum mechanics that had remained unchecked since the thirties. Most of the related theoretical work has been receiving renewed interest.

The Quantum Information Group (GIQ) brings together researchers attached to the Autonomous University of Barcelona (UAB) whose work is mainly focused in the field of quantum information and entanglement. GIQ is not an official entity but includes the whole membership of the QUIRT I & II (Quantum Information and Related Topics) projects financed by the Spanish Ministry of Science and Technology (MCyT), the European Tematic Networks QUPRODIS IST2002 and SCALA (FP6-2004-IST-FET Proactive). The GIQ has the official title of "Consolidated Team", granted by the Generalitat de Catalunya, the Catalan local government, from whom it also receives financial support, and since 2006 it is a node of the

CONSOLIDER-INGENIO 2010 project QOIT (CSD2006-00019), devoted to quantum information with photons.

The GIQ research has become a reference in some of the topics developed by members of the team. The research of the GIQ has very high visibility with many publications in the highest impact journals and contributions to congresses. The group has also established collaborations with leading international research groups, to mention a few: Garching (Prof. I. Cirac), Copenhagen (Prof. Polzik), Leiden (Prof. Gill), Sendai (Prof. Hayashi), New Mexico (Prof. Caves), Darmstadt (Prof. Birkel), Innsbruck (Prof. Briegel), etc.

The main research lines of the GIQ are: optimization of communication strategies and estimation of quantum operations taking into account realistic conditions for its physical implementation; classification and characterization of quantum tasks using systems of continuous variables; entangled pairs of particles; Bell inequalities, complementarity and quantum eraser; characterization of the dynamical properties of the entanglement in strongly correlated ultra-cold quantum gases and spin gases, and the design of photonic quantum gates for quantum computing.

During 2007, the IFAE members of GIQ have mainly focused in estimation/discrimination and communication aspects of quantum information.

1) We have considered the problem of communicating intrinsic information (information that cannot be digitized, such as a direction in space in the absence of a shared reference frame between sender and recipient) secretly to multiple recipients in such a way that they can unveil the secret message only if they act collectively. We have introduced a quantum protocol that accomplish this task. An interesting variation is secret time synchronization, which is currently work in progress.

2) A fundamental problem in information theory (either quantum or classical) is to find a protocol to

discriminate between two hypothesis given some data, usually the results of sampling the two distribution probabilities associated to the two hypothesis. Typically, the error probability vanishes exponentially with the size of the sample. The exponential rate with which the error probability goes to zero is a fundamental quantity known as the Chernoff bound. We have solved the long-standing problem of finding the quantum version of this quantity, which has profound implications in quantum information.

3) The sensitivity in quantum metrology can be greatly improved by using strongly interacting

systems whose Hamiltonians are non-linear (they contain non-linear interactions). We show that the performance of simple product states in these type of protocols is essentially optimal, in the sense that it leads to a scaling of the sensitivity as a function of the size of the system that differ only by the small constant  $1/2$  from that attained with entangled states (much more resource consuming).

4) We have also studied the measurement of the entanglement between two photons carried by the orbital angular momentum.

# 7.10 Theoretical Astroparticle and Particle Cosmology

(Eduard Massó)

---

The general goal of the research line is to study some of the theoretical issues in the physics of elementary particles and their interactions, particularly when we have an astrophysical or cosmological medium. In these media one has some processes that are suppressed in laboratory conditions, or at least they occur differently. Thus, the results that we obtain in our research complement and enrich the information obtained in laboratory experiments. In fact, the flux goes both ways: data from laboratory experiments can illuminate the physics of some of the aspects of star and universe evolution.

Our work is phenomenology-oriented and thus it is intimately linked to experiments, both laboratory type (high energy accelerators as LEP and LHC at CERN, low energy detectors, etc.) and observational (ground-based and satellite borne telescopes, etc).

It is very widely recognized that the fields of Astroparticles and Particle Cosmology are in progressive expansion. One major discovery has been neutrino oscillations, detected from the analysis of atmospheric and solar neutrinos. This is very important for neutrino physics, in which we have been involved since many years and is one of the main activities of our group. Other recent discoveries with impact in our field refer to the anisotropies of the microwave background, and the determinations of distances to supernovas. The emerging scenario from the analysis of all these observations is very interesting, and one is faced by very fundamental questions. With our research we would like to contribute to these developments.

We list our main efforts in 2007:

1) We investigated the effect on the CMB anisotropy at large angular scales coming from a large curvature before inflation. We calculated the density perturbations for both open and closed universe cases using the Bunch-Davies vacuum condition on the initial state. We found that our power spectrum gives a lower quadrupole anisotropy when  $\Omega-1 > 0$ ,

but matches the temperature anisotropy calculated from the standard Ratra-Peebles power spectrum at large  $l$ . The determination of spatial curvature from temperature anisotropy data is not much affected by the different power spectra which arise from the choice of different boundary conditions for the inflaton perturbation.

2) We pointed out that a light scalar particle coupling to two photons induces coupling to protons and leads to non-newtonian forces. We have shown that the experimental constraints on exotic, fifth-type forces lead to stringent constraints on the  $\Phi\gamma\gamma$  coupling.

3) We have studied the phenomenological consequences of the existence of long-range forces coupled to lepton flavour numbers in solar neutrino oscillations. We have considered electronic forces mediated by scalar, vector or tensor neutral bosons and analyzed their effect on the propagation of solar neutrinos as a function of the force strength and range. We found that, generically, the inclusion of the new interaction does not lead to a very statistically significant improvement on the description of the data in the most favored MSW LMA (or LMA-I) region. It does, however, substantially improve the fit in the high- $\Delta m^2$  LMA (or LMA-II) region which can be allowed for vector and scalar lepto-forces (in this last case if neutrinos are very hierarchical) at  $2.5\sigma$ . Conversely, the analysis allowed us to place stringent constraints on the strength versus range of the leptonic interaction.



# 7.11 Physics of the Fundamental Interactions

(Alex Pomarol)

There is a tremendous amount of experimental evidence that the Standard Model (SM) is fundamentally correct at the scales of energy and at the level of accuracy that we have explored so far. Nevertheless, there are plenty of open fundamental questions to which the SM does not give us an answer. For example, we do not know the origin of the neutrino masses, the reason of the particle-antiparticle asymmetry in the universe, which particle accounts for the dark matter of the universe, the mechanism of electroweak symmetry breaking (EWSB), or, more importantly, we do not know how gravity can be consistently incorporated as a quantum field theory along the other fundamental interactions.

The Large Hadron Collider (LHC) at CERN can shed information on the above fundamental questions. This accelerator will produce particle collisions at energies well above the electroweak scale, and therefore it will allow us to explore the physics responsible for EWSB. This new physics can not only be crucial for unraveling the nature of particle masses and flavor mixings, but also for the comprehension of the origin of matter and dark matter in our universe. Our group is devoted to study the different theoretical scenarios that can be found at the LHC above the electroweak scale. Examples of this physics beyond the SM are supersymmetry, extra dimensions or string theory, as well as more exotic scenarios such as "unparticle" physics.

Some aspects of the SM as precision flavor physics and nonperturbative strong interactions will play a major role at the LHC. Our group has also been interested in a deeper understanding of the nonperturbative dynamics of QCD. For this purpose, experiments at lower energies than the LHC have been very important to get a better understanding of hadron physics, and to develop theoretical methods to obtain reliable theoretical predictions.

During the year 2007 the theory group was involved in the following activities concerning flavor and QCD physics:

1) We carried out a phenomenological analysis of radiative meson decays with the purpose of determining the gluonic content of the eta and eta' wave functions. Using flavour symmetries, we have also provided a set of sum rules relating CP-averaged ratios and CP-asymmetries of  $B \rightarrow \pi\eta'$ ,  $K\eta'$ ,  $\eta'\eta'$  decays.

2) We have calculated the scalar contributions to the radiative decay  $\Phi \rightarrow KK\gamma$  and  $\Phi \rightarrow f_0\gamma$ ,  $\Phi \rightarrow a_0\gamma$  within the framework of the Linear Sigma Model.

3) We have derived a new sum-rule based on an IR safe quantity to obtain the CKM angle alpha from the recently measured  $B \rightarrow K^0\bar{K}^0$ . Three different strategies were proposed to obtain the weak mixing phase of the  $B_s$  system using longitudinal observables based on decays of B mesons into vectors.

4) We have studied the  $K^*$  polarization states in the exclusive B meson 4-body decay  $B^0 \rightarrow K^{*0}(\rightarrow K\pi)\ell^+\ell^-$  in the low dilepton mass region. We have proposed and studied different observables at NLO in QCD Factorization, including possible  $\Lambda/m_b$  corrections. We have evaluated the possible impact that right-handed currents coming from supersymmetry can have on those observables.

5) We have studied the constraints that the operator product expansion imposes on large  $N_c$  inspired QCD models for current-current correlators. We have computed the static potential associated to the locally 1/2 BPS Wilson loop in N=4 supersymmetric Yang-Mills theory with  $(\lambda^2/r)$  accuracy. We also resummed the leading logarithms, of  $O(\lambda^{n+1}\ln^n \lambda/r)$ .

6) We have computed the spin-independent structure functions of the forward virtual-photon Compton tensor of the proton at one loop using heavy baryon chiral perturbation theory and dispersion relations. We then computed the leading chiral term of the polarizability correction to the Lamb shift of the hydrogen and muonic hydrogen.

Also, we list the activities in physics beyond the Standard Model:

7) We have proven that in the Randall-Sundrum model where the radion is stabilized by a Goldberger-Wise potential there is a supercooled transition from a deconfined to a confined phase at temperatures orders of magnitude below the typical Standard Model critical temperature. This generates the possibility of having the out-of-equilibrium condition required by electroweak baryogenesis in the electroweak phase transition.

8) The Higgs boson offers a unique window to hidden sectors via relevant (or marginal) operators. Such interactions can provide new patterns for electroweak breaking and trigger a strong enough first order phase transition. Hidden sectors will be identified with singlet particles and unparticle operators. In both cases we have shown how the

hidden sector affects dramatically the mechanism of electroweak breaking.

9) We have proposed a new scenario for EWSB based on a Pseudo-Goldstone Boson Higgs, and studied its implications at the LHC. This scenario can arise from warped extra dimensions and predicts new exotic colored fermions of electromagnetic charges  $5/3$ ,  $2/3$  and  $-1/3$ , with masses predicted roughly in the range 500-1500 GeV. We have studied how to produce and detect them at the LHC.

10) We have analyzed the implications of having a composite Higgs at future colliders, and how to distinguish it from an elementary SM Higgs. Phenomenological prospects for the LHC and the ILC have been studied, including the study of high-energy longitudinal vector boson scattering, strong double-Higgs production and anomalous Higgs couplings.